

# OPERATION AND MAINTENANCE MANUAL

## SEQUOIA™ CHECK VALVE



# AMERICAN

FLOW CONTROL

THE RIGHT WAY



# INDEX

## SEQUOIA™ CHECK VALVE

	Page
<b>FEATURES</b> .....	2D-2
<b>ORDERING</b>	
Dimensions.....	2D-3
Submittal Sheet.....	2D-4
<b>INSTALLATION AND TESTING</b>	
Installation.....	2D-5, 2D-6
Testing.....	2D-7, 2D-8, 2D-9
<b>OPERATION AND MAINTENANCE</b>	
Operation and Maintenance.....	2D-10, 2D-11
Troubleshooting Guide.....	2D-12
<b>REPAIRS</b>	
Parts List.....	2D-13
Traffic Repair Instructions.....	2D-14
Field Disassembly Instructions.....	2D-15
Field Assembly Instructions.....	2D-16
<b>SPECIFICATIONS</b> .....	2D-17

## SEQUOIA™ CHECK VALVE FEATURES



### Features

The AMERICAN Flow Control **SEQUOIA™** Check Valve meets or exceeds applicable requirements of ANSI/AWWA C503 with 350 psig rated working pressure and features a compact ductile iron body for ultimate strength and durability.

The SEQUOIA check valve has superior flow performance offering head loss of .5 psi at 1000 gallons per minute. The disc is made of bronze with an easy-to-reset 316 stainless steel activation assembly and encapsulated EPDM valve rubber. The interior surfaces of the body are fusion bonded epoxy-coated in accordance with ANSI/AWWA C550. Two indicator holes allow for indication of valve break and pressure release with approximately 10 gpm total flow through indicator holes at 100 psig line pressure.

# SEQUOIA™ CHECK VALVE DIMENSIONS

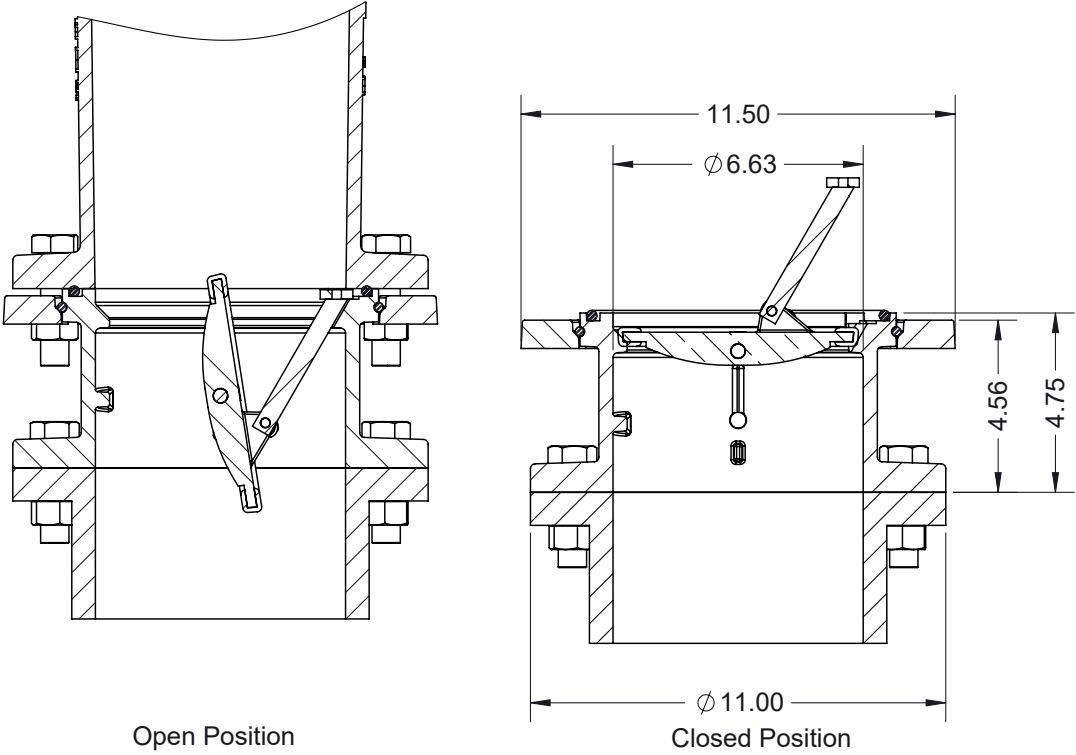

IL8603

AMERICAN Flow Control®  
SEQUOIA™ CHECK VALVE  
SUBMITTAL SHEET



City Specification: _____ Quantity: _____
Body (lower) Flange Machining Option: (Check One) <input type="checkbox"/> ANSI Eight-Bolt <input type="checkbox"/> AWWA C503 Six-Bolt <input type="checkbox"/> San Diego Six-Bolt
Breakable (upper) Flange Machining Option: (Check One) <input type="checkbox"/> ANSI Eight-Bolt <input type="checkbox"/> AWWA C503 Six-Bolt <input type="checkbox"/> San Diego Six-Bolt
Other Requirements: (List)

**NOTES:**

1. Meets or exceeds applicable requirements of ANSI/AWWA C503 with 350 psig rated working pressure.
2. Interior surfaces of the body are fusion-bonded epoxy coated in accordance with ANSI/AWWA C550.
3. Certified to NSF/ANSI/CAN 61 and 372.

# SEQUOIA™ CHECK VALVE INSTALLATION INSTRUCTIONS



This instruction is issued as a recommendation to the customer for the proper use of the AMERICAN Flow Control® (AFC) SEQUOIA™ Check Valve. AFC recommends following the general inspection and installation guidelines outlined in AWWA Manual M17 for installation, field testing, and maintenance of fire hydrants in combination with the recommendations below.

**WARNING: Special care should be taken in the installation, inspection and repair of pressure containing devices such as valves and hydrants. FAILURE TO FOLLOW PROPER PRACTICE AND GUIDELINES CAN RESULT IN SERIOUS INJURY OR DEATH. High pressure and water hammer, due to rapid opening or closing of a hydrant or valve, can also cause major damage to the hydrant, valve, water main, fire hose, or other attached equipment.**

## Receiving Inspection

On receipt, inspect for any damage that may have resulted from shipping. Report any problems to the carrier, note on bill of lading and have the driver sign recipient's copy. NOTE: All water lines related to the installation of the hydrant should be isolated, free from any pressure, and drained prior to installation.

## General Hydrant and Check Valve Installation Guidelines

1. When hydrants and check valves are received, they should be handled carefully to avoid damage. Protect stored products from the elements. Rubber components should not be exposed to direct sunlight for extended periods. Whenever possible, cover the products with a waterproof covering.
2. Before installation of the check valve and hydrant, clean flanges, valve disc, and valve seat of any rocks, sand and/or foreign material. Indicator holes in the valve disc should be inspected for blockage.
3. Locate hydrants as detailed in AWWA M17 and/or in accordance with applicable fire codes, the requirements of local fire authority, or any applicable municipal design standard.
4. All hydrants shall stand plumb and have outlets oriented as shown or as directed by the engineer, owner, or governing authority. The check valve breakable flange allows 360° rotation of the hydrant during installation. The top flange of the check valve should be installed 4
5. to 6 inches above the established grade to allow free swing of wrenches when operating the hydrant and for best performance of traffic impact feature.
6. As recommended in AWWA M17, install an auxiliary or secondary gate valve in the lateral between the hydrant and the main to permit inspection or repair of the hydrant and check valve without shutting down mains. The use of AMERICAN Flow Control® Series 2500 Resilient Wedge Gate Valves is recommended.
7. Restrain hydrant movement with appropriate thrust blocking and any specified restraint. In soft soil conditions, a support collar should be poured just below grade to provide additional support during a potential traffic impact. Failure to properly restrain the hydrant may prevent proper operation of the check valve during a traffic impact.
8. Once installed, the SEQUOIA™ hydrant and check valve should be hydrostatically tested and flushed. Ideally this will be done prior to backfilling. See the following sections.

# SEQUOIA™ CHECK VALVE INSTALLATION INSTRUCTIONS



This instruction is issued as a recommendation to the customer for the proper use of the AMERICAN Flow Control® (AFC) SEQUOIA™ Check Valve. AFC recommends following the general inspection and installation guidelines outlined in AWWA Manual M17 for installation, field testing, and maintenance of fire hydrants in combination with the recommendations below.

**WARNING: Special care should be taken in the installation, inspection and repair of pressure containing devices such as valves and hydrants. FAILURE TO FOLLOW PROPER PRACTICE AND GUIDELINES CAN RESULT IN SERIOUS INJURY OR DEATH. High pressure and water hammer, due to rapid opening or closing of a hydrant or valve, can also cause major damage to the hydrant, valve, water main, fire hose, or other attached equipment.**

## Installation Instructions

1. Ensure all mating surfaces are clean, and free of any corrosion, dirt, or debris.
2. Carefully position flange gasket between check valve and vertical inlet lead (lower bury ell). Bolt check valve to the vertical inlet lead in accordance with gasket manufacturer recommendations.
3. Ensure the flange O-ring (9) is free of abrasion, stretching, and cuts and lubricate heavily with AFC approved food grade grease.
4. Install O-ring in the top flange groove in the check valve body (1).
5. Place the break flange (10) over the upper flange with the chamfered inner mating surface facing up.
6. Install the lock ring (11) in the upper flange groove, ensuring that it is fully seated in the groove.
7. Position the disc (4) in the open position and ensure that the activation assembly (8) is properly seated in the check valve body (1) and flush with the top flange.
8. Place hydrant on check valve and orient as desired. Ensure that the hydrant is centered on the check valve.
9. Install bolts, hand-tightening until snug. Torque bolts in two stages, **first to 30 ft-lbs. and then to 50 ft-lbs.** in a star pattern.
  - a. **ENSURE THAT THE BREAK FLANGE IS IN EVEN CONTACT WITH THE SNAP RING AND IS PARALLEL WITH HYDRANT FLANGE PRIOR TO TORQUING BOLTS. Uneven contact may cause flanges to crack when bolts are torqued.**
  - b. **DO NOT USE POWER TOOLS TO INSTALL BREAK FLANGES. Use of power tools may result in excessive torque on bolts and crack the breakable flange.**
10. Open the hydrant isolation valve and flush the hydrant. The check valve should not close during hydrant operation. If the check valve closes, remove the hydrant, and inspect the check valve for damage or improper installation.

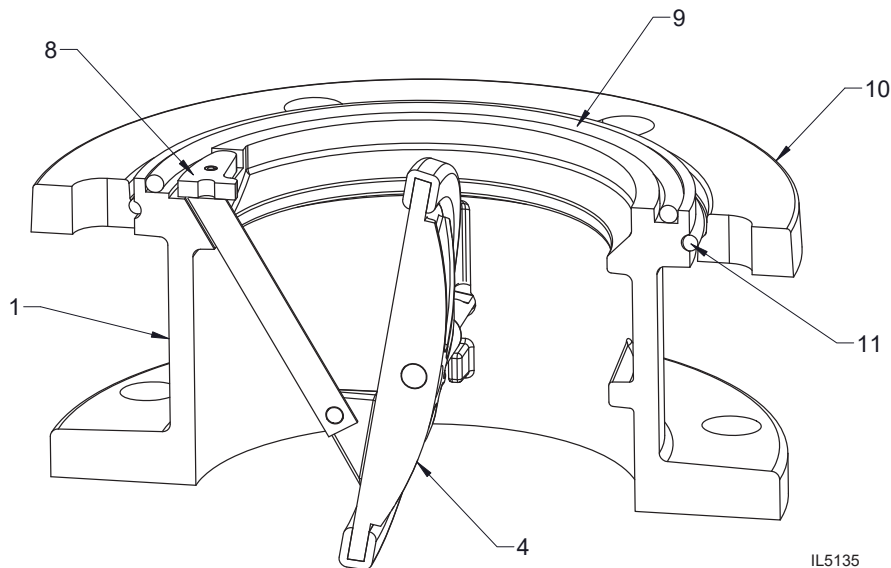

## SEQUOIA™ CHECK VALVE TESTING



AFC recommends following the general inspection and installation guidelines outlined in AWWA Manual M17 for installation, field testing, and maintenance of fire hydrants in combination with the recommendations below. The auxiliary valve should be closed during water main tests (see ANSI/AWWA C600).

**WARNING: Special care should be taken in the installation, inspection and repair of pressure containing devices such as valves and hydrants. FAILURE TO FOLLOW PROPER PRACTICE AND GUIDELINES CAN RESULT IN SERIOUS INJURY OR DEATH. High pressure and water hammer, due to rapid opening or closing of a hydrant or valve, can also cause major damage to the hydrant, valve, water main, fire hose, or other attached equipment.**

### Pressure Test at Main Pressure

1. Ensure that the auxiliary shut-off gate valve and all hydrant valves are closed. Do not over-torque valves.
2. Inspect all hydrant caps to ensure that the pressure relief hole is clear of debris or paint to prevent the possibility of pressure buildup between closed valves and caps.
3. Remove cap from the upper-most valve on hydrant body.
4. Open auxiliary shut-off gate valve.
5. Open upper-most valve 3-4 turns or until flow is heard.
6. Close the upper-most valve once steady flow out of nozzle is seen.
7. The hydrant is now at full main pressure.
8. Check for leakage at all joints and outlets.
9. If necessary, safely repair hydrant and/or check valve using the instructions found in this publication.
10. Repeat the test until the results are satisfactory.
11. At test conclusion, fully close the hydrant and ensure auxiliary shut-off gate valve is fully open.



**WARNING: Special care should be taken in the installation, inspection and repair of pressure containing devices such as valves and hydrants. FAILURE TO FOLLOW PROPER PRACTICE AND GUIDELINES CAN RESULT IN SERIOUS INJURY OR DEATH. High pressure and water hammer, due to rapid opening or closing of a hydrant or valve, can also cause major damage to the hydrant, valve, water main, fire hose, or other attached equipment.**

### **Pressure Test at Pressures Above Main Pressure**

1. Ensure that the auxiliary shut-off gate valve and all hydrant valves are closed. Do not over-torque valves.
2. Inspect all hydrant caps to ensure that the pressure relief hole is clear of debris or paint to prevent the possibility of pressure buildup between closed valves and caps.
3. Connect a pressure test pump to one of the lower hydrant outlets and open the respective valve.
4. Remove cap from the upper-most valve on hydrant body.
5. Open auxiliary shut-off gate valve.
6. Open upper-most valve 3-4 turns or until flow is heard.
7. Close the upper-most valve once steady flow out of nozzle is seen.
8. Close the auxiliary valve.
9. Safely pump up to the test pressure but do not exceed the rated working pressure of the hydrant or system components.
10. Check for leakage at all joints and outlets.
11. Safely repair hydrant and/or check valve using the instructions found in this manual.
12. Repeat the test until the results are satisfactory.
13. At test conclusion, relieve test pump pressure.
14. At test conclusion, fully close the hydrant valves, replace nozzle caps, and ensure auxiliary shut-off gate valve is fully open.



**WARNING: Special care should be taken in the installation, inspection and repair of pressure containing devices such as valves and hydrants. FAILURE TO FOLLOW PROPER PRACTICE AND GUIDELINES CAN RESULT IN SERIOUS INJURY OR DEATH. High pressure and water hammer, due to rapid opening or closing of a hydrant or valve, can also cause major damage to the hydrant, valve, water main, fire hose, or other attached equipment.**

### **Placing a Hydrant and Check Valve in Service**

1. After testing and backfilling, the hydrant and check valve should be safely flushed and tested to be sure that it is bacteriologically safe before it is put into service.
2. Close all outlet valves. Ensure that auxiliary shut-off gate valve is fully open.
3. Inspect all hydrant caps to ensure that the pressure relief hole is clear of debris or paint to prevent the possibility of pressure buildup between closed valves and caps.
4. Clean the hydrant and check valve exterior to remove dirt accumulated during installation. Touch up any areas where factory coating was damaged during handling or installation. Use an appropriate top coating or contact factory for touch-up coatings.



**WARNING: Special care should be taken in the installation, inspection and repair of pressure containing devices such as valves and hydrants. FAILURE TO FOLLOW PROPER PRACTICE AND GUIDELINES CAN RESULT IN SERIOUS INJURY OR DEATH. High pressure and water hammer, due to rapid opening or closing of a hydrant or valve, can also cause major damage to the hydrant, valve, water main, fire hose, or other attached equipment.**

## Operation

AFC recommends following the general inspection and installation guidelines outlined in AWWA Manual M17 for installation, field Testing, and maintenance of fire hydrants in combination with the recommendations below.

1. Check the direction of opening as marked on the stuffing box.
2. Make sure all hydrant valves are in the closed position.
3. Inspect all hydrant caps to ensure that the pressure relief hole is clear of debris or paint to prevent the possibility of pressure buildup between closed valves and caps.
4. Remove cap from valve outlet to be operated.
5. Slowly and consistently open valve 12-14 turns.

### NOTES:

- Always operate the hydrant fully open. The hydrant valve is not intended for throttling.
  - The stuffing box limits the open position. Do not force the hydrant beyond fully open as indicated by sudden resistance to turning.
6. To close, turn the valve until the flow is stopped. It is not necessary to close the hydrant valve with great force. The valve will be assisted by mains pressure in sealing. If the hydrant does not shut off completely, do not attempt to force the hydrant to close. See troubleshooting guide in this manual.



**WARNING: Special care should be taken in the installation, inspection and repair of pressure containing devices such as valves and hydrants. FAILURE TO FOLLOW PROPER PRACTICE AND GUIDELINES CAN RESULT IN SERIOUS INJURY OR DEATH. High pressure and water hammer, due to rapid opening or closing of a hydrant or valve, can also cause major damage to the hydrant, valve, water main, fire hose, or other attached equipment.**

### Inspection

1. It is recommended that hydrants and check valves be inspected twice per year to ensure satisfactory operation.
2. Routine inspection should cover the points outlined in AWWA Manual M17 and include (but not be limited to) the following points:
  1. External inspection of hydrant, check valve, and any attached accessories for damage, corrosion, paint condition, etc.
  2. Inspecting valves for leakage.
  3. Inspect all hydrant caps to ensure that the pressure relief hole is clear of debris or paint to prevent the possibility of pressure buildup between closed valves and caps.
  4. Statically testing the system to look for leakage at connections. (See pressure test at main pressure)
  5. Cycling the hydrant from full open to full close. (See operation)
  6. Verifying that the traffic break check valve does not close under hydrant flow.
  7. Ensuring hydrant and attached accessories are properly lubricated.
3. At the time of inspection, flush the hydrant to remove any foreign material from the system.

### Maintenance

AFC strongly recommends that following routine maintenance on fire hydrants as outlined in AWWA Manual M17 for Installation, Field Testing, and Maintenance of Fire Hydrants. The ease of operation and the frequency of repair depends on the condition of the water system and maintenance practices. Valve operating components of wet barrel hydrants are in constant contact with the water system and routine exercising is key to ensuring smooth and reliable operation valves over the life of the hydrant. Dirt, gravel, and other foreign material in the hydrant may prevent it from closing or operating smoothly. This can also result in damage to the valve rubber. Under most operating conditions, AFC recommends semi-annual lubrication and inspection of fire hydrants.

**Note: Where grease is specified, use AFC recommended wet-barrel hydrant grease. USE OF A NON-AFC RECOMMENDED GREASE MAY NOT BE COMPATIBLE WITH EPDM SEALS AND AFFECT HYDRANT PERFORMANCE AND LONGEVITY.**

1. Twice per year, open the hydrant completely and flush for several minutes. Open and close all hydrant valves to ensure proper operation and check for leaks.
2. Ensure proper lubrication of the operating mechanism. Valve operating components in wet barrel fire hydrants are exposed to the water system and grease will wash away overtime during operation.
3. If hydrant fails to operate properly and smoothly, see the troubleshooting guide in this manual.

## SEQUOIA™ CHECK VALVE TROUBLESHOOTING GUIDE



**WARNING:** Special care should be taken in the installation, inspection and repair of pressure containing devices such as valves and hydrants. **FAILURE TO FOLLOW PROPER PRACTICE AND GUIDELINES CAN RESULT IN SERIOUS INJURY OR DEATH.** High pressure and water hammer, due to rapid opening or closing of a hydrant or valve, can also cause major damage to the hydrant, valve, water main, fire hose, or other attached equipment.

Problem	Solutions
Hydrant valve does not shut off completely.	<ol style="list-style-type: none"> <li>1. Debris may be trapped in the valve seat preventing the hydrant from fully closing. With a cap removed, partially open and close the hydrant several times to dislodge the debris.</li> <li>2. Flush problematic valve in fully open position.</li> <li>3. Safely disassemble, inspect, clean, and repair the hydrant valve using the instructions found in this publication.</li> </ol>
Ground around hydrant is highly saturated.	<ol style="list-style-type: none"> <li>1. Inspect valves, external seals, and above-ground connections for leakage or signs of leakage.</li> <li>2. If a hydrant valve(s) is leaking, follow steps in the SEQUOIA Hydrant Manual to repair.</li> <li>3. If seals other than valve(s) are leaking, inspect and repair the seal using the instructions found in this publication.</li> <li>4. The lower bury ell connection to the main may be leaking. This will require excavation of the hydrant bury section.</li> </ol>
Leakage from the hex head plugs.	<ol style="list-style-type: none"> <li>1. Close hydrant isolation valve and relieve pressure.</li> <li>2. Remove hex head plugs and inspect for presence of the plug O-ring.</li> <li>3. If an O-ring is present, ensure that it is free of cuts, abrasion, and tearing.</li> <li>4. Replace plug(s) if necessary.</li> </ol>
No flow through hydrant with traffic break check valve installed.	<ol style="list-style-type: none"> <li>1. Check that hydrant isolation valve is open.</li> <li>2. Close the hydrant isolation valve. Check valve activation lever may have come free, allowing check valve to close. Follow check valves installation and inspection instructions to remove hydrant and inspect check valve for unintended closure.</li> </ol>

# SEQUOIA™ CHECK VALVE PARTS LIST

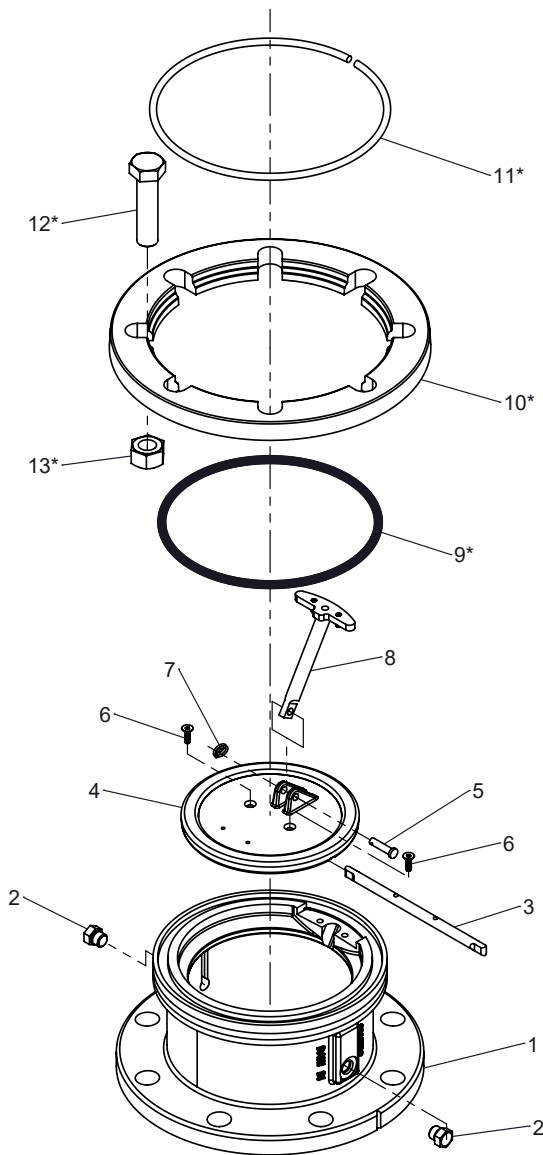

IL8603

REF No.	QTY	DESCRIPTION	MATERIAL
1	1	Body	Ductile Iron, ASTM A536 Grade 65-45-12, Interior Surfaces Epoxy Coated, ANSI/AWWA C550
2	2	Hex Head Plug	Stainless Steel, Type 316
3	1	Shaft	Stainless Steel, Type 316
4	1	Disc	EPDM Encapsulated Bronze, ASTM B584, UNS C87600
5	1	Clevis Pin, ¼ x 1-1/8"	Stainless Steel, Type 316
6	2	Flat Head Hex Socket Screw, 10-32 x 5/8"	Stainless Steel, Type 316
7	1	Kickout Ring	Stainless Steel, Type 302
8	1	Activation Assembly	Stainless Steel
9*	1	O-ring	EPDM
10*	1	Breakable Flange	Cast Iron, ASTM A48, Class 40B
11*	1	Flange Lock Ring	Stainless Steel, Type 430
12*	8**	Hex Head Bolt	Stainless Steel, Type 316
13*	8**	Hex Nut	Stainless Steel, Type 316

\* Note: These parts are shipped loose and are assembled to the check valve at the time of installation.

\*\* Note: Bolt quantities vary based on bolt pattern ordered.

## SEQUOIA™ CHECK VALVE TRAFFIC REPAIR INSTRUCTIONS



After a traffic impact occurs, SEQUOIA hydrants and check valves should be repaired using Repair Kits K1308-1 (C503 Bolt Pattern), K1308-2 (ANSI 8 Bolt Pattern), or K1308-3 (San Diego Bolt Pattern).

**WARNING: Special care should be taken in the installation, inspection and repair of pressure containing devices such as valves and hydrants. FAILURE TO FOLLOW PROPER PRACTICE AND GUIDELINES CAN RESULT IN SERIOUS INJURY OR DEATH. High pressure and water hammer, due to rapid opening or closing of a hydrant or valve, can also cause major damage to the hydrant, valve, water main, fire hose, or other attached equipment.**

### Traffic Repair

1. Shut off the water line supplying the hydrant.
2. Flow through the indicator holes should slow and stop as pressure is relieved. Check valve disc may drop into the open position. If the hydrant has not broken completely away, the check valve may not have closed.  
**WARNING: If flow continues through the indicator holes, STOP, and check that hydrant isolation valve is fully closed and operational.**
3. Remove any bolts and pieces of breakable flange from the hydrant and check valve flanges.
4. Clean any debris from the hydrant and check valve.
5. The hydrant should be inspected for external damage, including caps, stem nuts, valve stems, and nozzles. All valves should be fully exercised to ensure that no damage has occurred. If valve(s) fail to exercise fully and smoothly, follow the relevant instructions in the SEQUOIA Hydrant Operation and Maintenance manual.
6. The check valve should be inspected for damage. **Replacement parts for the following components are not provided in the traffic repair kit as standard and must be ordered separately if damage has occurred.**
  - a. Body (1) – Damage to body and top flange.
  - b. Shaft (3) – Bending or other damage.
  - c. Valve Disc (4) – Tearing or damage to valve rubber. Bending or other damage to the activation assembly mounting lugs.
  - d. Activation Assembly (8) – Bending or other damage.
  - e. Clevis Pin (5) and Kickout Ring (7) – Bending or other damage.
7. Replace any parts identified as damaged in step 6, following the relevant repair instructions found in this manual.
8. Ensure all mating surfaces are clean, and free of any corrosion, dirt, or debris.
9. Replace the flange O-ring (9) in the top flange groove in the check valve body (1). Ensure it is free of abrasion, stretching, and cuts and lubricate heavily with AFC approved food grade grease.
10. Place the break flange (10) over the upper flange with the chamfered inner mating surface facing up.
11. Install the Lock Ring (11) in the upper flange groove, ensuring that it is fully seated in the groove.
12. Position the Disc (4) in the open position and ensure that the activation assembly (8) is properly seated in the check valve body (1) and flush with the top flange.
13. Place hydrant on check valve and orient as desired. Ensure that the hydrant is centered on the check valve.
14. Install bolts, hand-tightening until snug. Torque bolts in two stages, **first to 30 ft-lbs. and then to 50 ft-lbs.** in a star pattern.
  - a. **ENSURE THAT THE BREAK FLANGE IS IN EVEN CONTACT WITH THE SNAP RING AND IS PARALLEL WITH HYDRANT FLANGE PRIOR TO TORQUING BOLTS. Uneven contact may cause flanges to crack when bolts are torqued.**
  - b. **DO NOT USE POWER TOOLS TO INSTALL BREAK FLANGES. Use of power tools may result in excessive torque on bolts and crack the breakable flange.**
15. Perform a static pressure test of the hydrant and check valve.
16. Repair any coating damage using an AFC Paint Repair kit.



**WARNING:** Special care should be taken in the installation, inspection and repair of pressure containing devices such as valves and hydrants. **FAILURE TO FOLLOW PROPER PRACTICE AND GUIDELINES CAN RESULT IN SERIOUS INJURY OR DEATH.** High pressure and water hammer, due to rapid opening or closing of a hydrant or valve, can also cause major damage to the hydrant, valve, water main, fire hose, or other attached equipment.

## Preparation

1. Shut off the water line supplying the hydrant.
2. Remove a nozzle cap (4, 26) and while standing behind the hydrant, crack the valve open to release pressure.  
**WARNING: If hydrant continues to flow, STOP, and check that hydrant isolation valve is fully closed and operational.**
3. Uninstall hydrant from check valve.
4. Uninstall the check valve from the lower bury ell.

## Check Valve Disassembly

1. Using a 5/8" socket or combination wrench, remove one of the hex head plugs (2) from the check valve body (1).
2. Using a 1/8" t-handle Allen key or a 1/8" hex bit with extension to remove the flat head screws (6) retaining the shaft (3) in the disc (4).
  - a. **Note: flat head screws are secured with LOCTITE® 243 (blue). Some force will be required for removal. Do not use a ball end Allen key as damage to the Allen key may result.**
3. Slide the shaft out through the hex head plug (2) hole in the check valve body (1).
4. The valve disc (4) and activation assembly (8) can now be removed through the bottom of the check valve body (1).
5. The activation assembly (8) can be removed from the valve disc (4) by removing the clevis and kickout ring (5, 7).

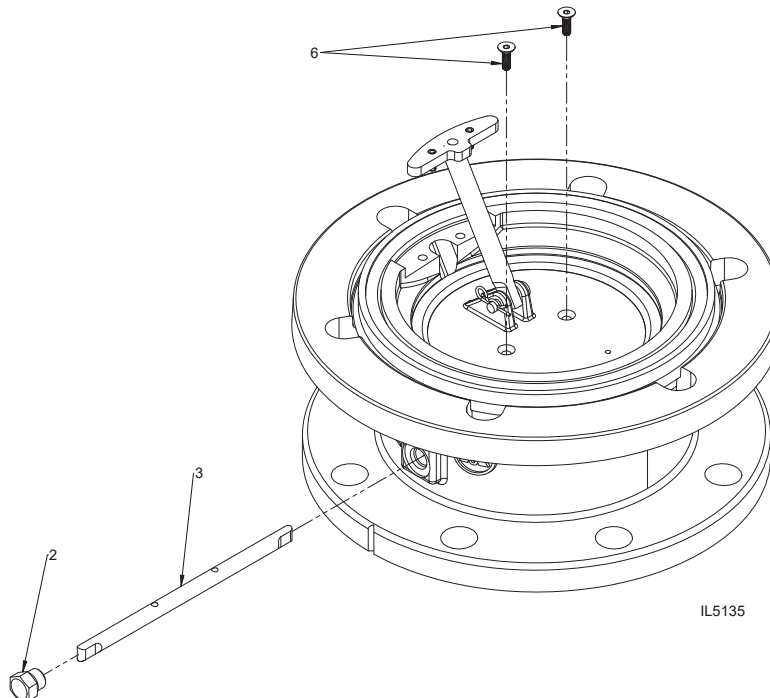



**WARNING: Special care should be taken in the installation, inspection and repair of pressure containing devices such as valves and hydrants. FAILURE TO FOLLOW PROPER PRACTICE AND GUIDELINES CAN RESULT IN SERIOUS INJURY OR DEATH. High pressure and water hammer, due to rapid opening or closing of a hydrant or valve, can also cause major damage to the hydrant, valve, water main, fire hose, or other attached equipment.**

**Check Valve Reassembly**

1. Ensure all mating surfaces are clean, and free of any corrosion, dirt, or debris.
2. Attach the activation assembly (8) to the check valve disc (4) using the clevis and kickout ring (5, 7).
  - a. **Note the orientation of the activation assembly relative to the mounting lugs on the valve disc as shown in the figure below.**
3. Install the check valve disc and activation assembly into the body (1) from the bottom.
  - a. **Note the orientation of the valve disc and activation assembly relative to the retention pocket in the body as shown in the figure below.**
4. Slide the shaft (3) into the valve disc (4) through the hole in the side of the body. Ensure that the threaded holes in the shaft line up with the holes in the valve disc.
5. Apply LOCTITE® 243 (blue) to the two flat head screws (6).
6. Thread the two flat head screws (6) into the shaft to secure it to the check valve disc.
7. Install the hex head plug (2) into the corresponding hole in the check valve body.
  - a. **Ensure that the plug o-ring is in place, is free of abrasion, stretching, and cuts, and is lubricated heavily with AFC approved food grade grease.**
8. Ensure that the valve disc and activation assembly move freely. Pull up on the activation assembly to check that the valve disc rotates and slides vertically to seal against the body valve seat.
9. Follow the installation instructions in this manual to correctly install the check valve and hydrant into service.

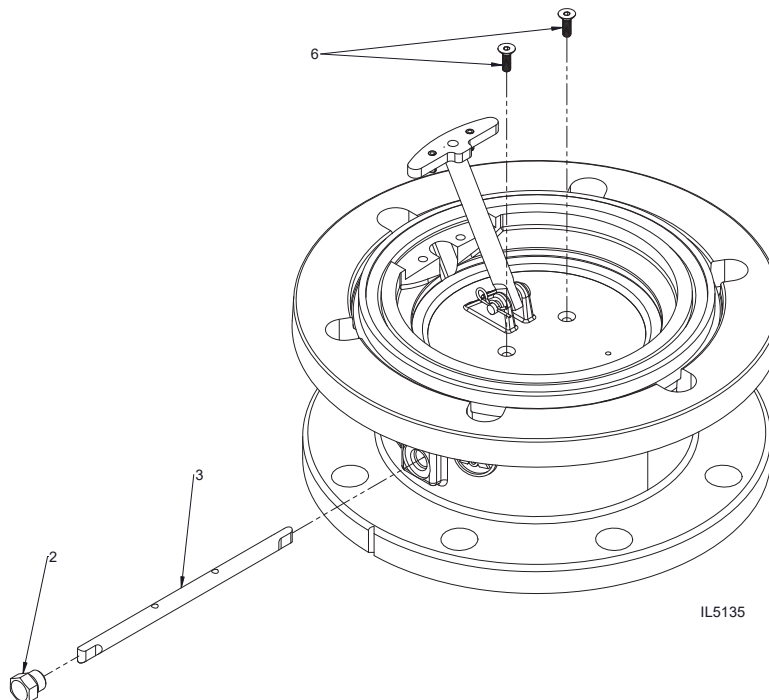

# SEQUOIA™ CHECK VALVE SPECIFICATIONS



## GENERAL

Wet barrel design  
Complies with the criteria referenced in Appendix C, of ANSI/AWWA C503  
Certified to NSF/ANSI/CAN 61 and NSF/ANSI/CAN 372  
Compliant with ANSI/AWWA C550  
Fully field serviceable  
O-ring seals at flanges  
Coatings:  
Exterior – Epoxy Primer and Two-Part Polyurethane Topcoat  
Interior – Epoxy Primer and Fusion Bonded Epoxy (FBE)  
Stainless steel hardware  
Pressure rating, 350 psi  
Pressure testing, 700 psi

## BODY

Flanged inlet with the following bolt patterns available:

C503 6-Bolt Pattern

ANSI Class 150 6" 8-Bolt Pattern

San Diego 6-Bolt Pattern

Full circumferential valve seat

## VALVE

Full bronze valve disc with 316 stainless steel shaft and encapsulated EPDM valve rubber  
2 indicator holes for indication of valve break and pressure release  
Approximately 10 gpm total flow through indicator holes at 100 psig line pressure



**AMERICAN**  
**FLOW CONTROL**  
**THE RIGHT WAY**

AMERICAN Flow Control  
P.O. Box 2727  
Birmingham, AL 35202-2727  
Phone: 800-326-8051  
Fax: 800-610-3569  
Email: [afcsales@american-usa.com](mailto:afcsales@american-usa.com)

Waterous Company  
125 Hardman Avenue South  
South St. Paul, MN 55075-2421  
Phone: 888-266-3686  
Fax: 800-601-2809  
Email: [afcsales@american-usa.com](mailto:afcsales@american-usa.com)

[WWW.AMERICAN-USA.COM](http://WWW.AMERICAN-USA.COM)



Product literature may become outdated. AMERICAN is not responsible for out-of-date information, errors or omissions.  
Product diagrams are illustrative only. Please contact AMERICAN for the most current product information.