

OPERATION AND MAINTENANCE MANUAL

4-3/4" WATEROUS TREND FIRE HYDRANT



AMERICAN

FLOW CONTROL

THE RIGHT WAY



INDEX

4-3/4" WATEROUS TREND FIRE HYDRANT

	Page
INTRODUCTION AND HISTORY	2A-2
ORDERING	
Dimensions:	
Overall Hydrant.....	2A-3
Optional Bottoms (Bases).....	2A-4
Operating Nut Sizes.....	2A-5
Weights.....	2A-6
Friction Loss.....	2A-7
Submittal Sheet.....	2A-8
INSTALLATION AND TESTING	
Installation.....	2A-9, 2A-10
Testing.....	2A-11, 2A-12
OPERATION AND MAINTENANCE	
Operation.....	2A-12
Maintenance.....	2A-13
Troubleshooting Guide.....	2A-14
REPAIRS	
Identifying Trend Variations.....	2A-15
Ordering Repair Parts.....	2A-15
Parts List:	
250 PSIG Rated Ductile Iron Trend (WB77-1).....	2A-16, 2A-17
200 PSIG Rated Gray Iron Trend (WB77).....	2A-18, 2A-19
Repair Instructions.....	2A-20 thru 2A-23
Traffic Damage Repair.....	2A-24, 2A-25
Nozzle Replacement.....	2A-26
Mechanically Attached Nozzles.....	2A-27, 2A-28
EXTENDING	
Extension Instructions.....	2A-29 thru 2A-32
SPECIFICATIONS	2A-33



4-3/4" WATEROUS TREND FIRE HYDRANT

AMERICAN Flow Control's **4-3/4" Waterous Trend** Fire Hydrant incorporates over 100 years of experience designing and manufacturing quality products for the water works industry. Introduced in 1977, the **4-3/4" Waterous Trend** hydrant's stylish and distinctive design provides real solutions to today's water system demands. The **4-3/4" Waterous Trend** hydrant is rated for 250 PSIG working pressure and meets or exceeds all of the requirements of ANSI/AWWA C502. Ductile iron construction throughout assures strength and durability. With many cities experiencing increased pressure to stretch their dollars, it is important to note that just one person can easily perform maintenance on the **4-3/4" Waterous Trend** hydrant. The removal of four bolts and nuts allows access to all of the working parts.

The **4-3/4" Waterous Trend** hydrant has all the features you expect from a high quality fire hydrant. The epoxy primer and polyurethane top coat system on external surfaces of the upper barrel provide a durable, high-gloss finish that will continue to look good for years without repainting. The all bronze valve seat and bronze seat insert help assure that the **4-3/4" Waterous Trend** hydrant remains easy to repair.

In 2006, the **4-3/4" Waterous Trend** hydrant adopted the basic design of the 5-1/4" Waterous Pacer Fire hydrant. This hydrant has been manufactured for almost forty years while continuing to maintain parts interchangeability. This allows you to truly standardize on a fire hydrant.

4-3/4" WATEROUS TREND - DIMENSIONS

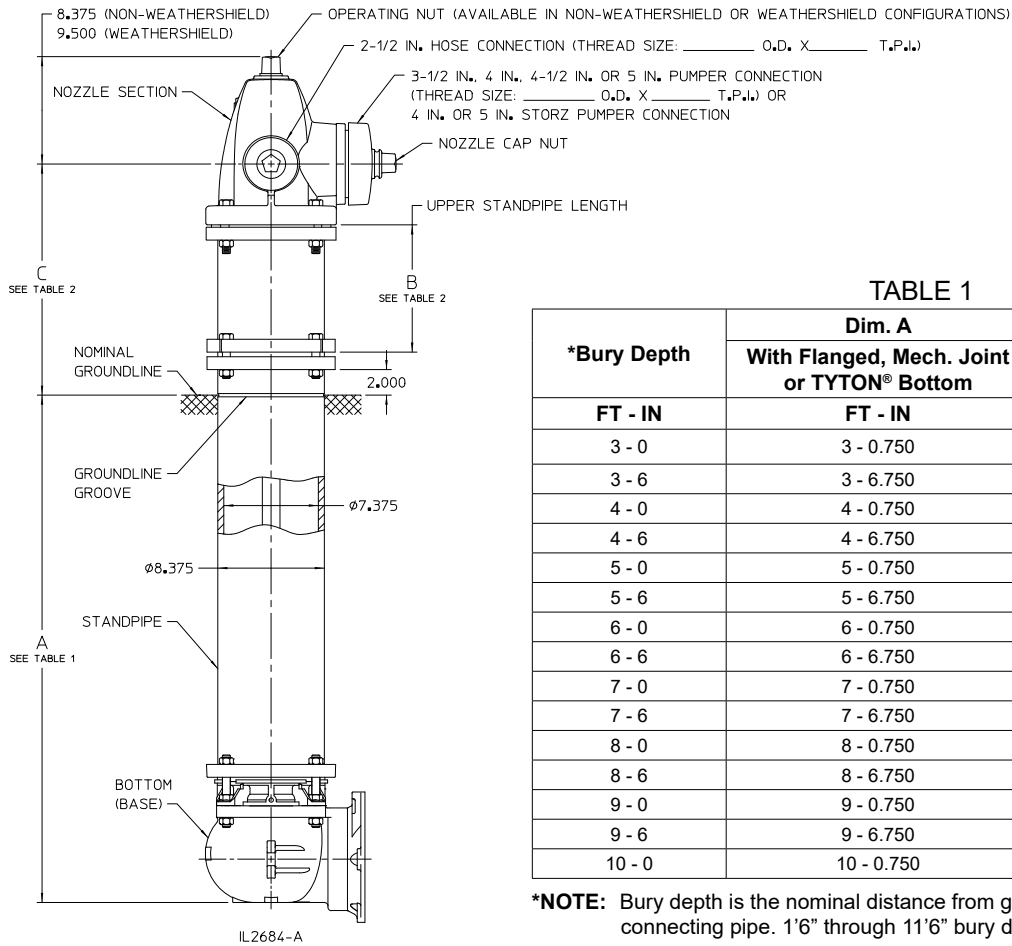

TABLE 1

*Bury Depth	Dim. A	Rod Length
	With Flanged, Mech. Joint or TYTON® Bottom	Traffic Model (Lower Rod Length)
FT - IN	FT - IN	FT - IN
3 - 0	3 - 0.750	2 - 9.312
3 - 6	3 - 6.750	3 - 3.312
4 - 0	4 - 0.750	3 - 9.312
4 - 6	4 - 6.750	4 - 3.312
5 - 0	5 - 0.750	4 - 9.312
5 - 6	5 - 6.750	5 - 3.312
6 - 0	6 - 0.750	5 - 9.312
6 - 6	6 - 6.750	6 - 3.312
7 - 0	7 - 0.750	6 - 9.312
7 - 6	7 - 6.750	7 - 3.312
8 - 0	8 - 0.750	7 - 9.312
8 - 6	8 - 6.750	8 - 3.312
9 - 0	9 - 0.750	8 - 9.312
9 - 6	9 - 6.750	9 - 3.312
10 - 0	10 - 0.750	9 - 3.312

*NOTE: Bury depth is the nominal distance from groundline to bottom of connecting pipe. 1'6" through 11'6" bury depths are available.

TABLE 2

DIM. B Upper Standpipe Length	DIM. C Nozzle Elevation Above Groundline
10 IN.	18 IN.
16 IN.	24 IN.
22 IN.	30 IN.
28 IN.	36 IN.
34 IN.	42 IN.

NOTES:

1. 250 PSIG rated working pressure
2. Meets or exceeds requirements of AWWA C502, latest revision.
3. Lower valve washer and hydrant bottom coated with fusion-bonded epoxy coating in accordance with ANSI/AWWA C550.
4. Certified to NSF/ANSI/CAN 61 and NSF/ANSI/CAN 372.
5. TYTON® is a registered trademark of United States Pipe and Foundry Co., LLC.
5. ALPHA™ is a trademark of Romac Industries, Inc. (U.S. Patent 8,894,100)

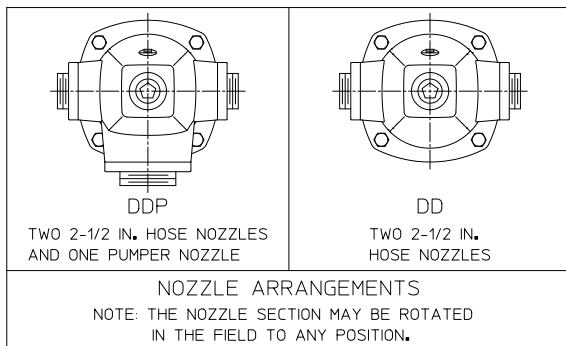

IL2684-B

4-3/4" WATEROUS TREND - DIMENSIONS, OPTIONAL BOTTOMS (BASES)

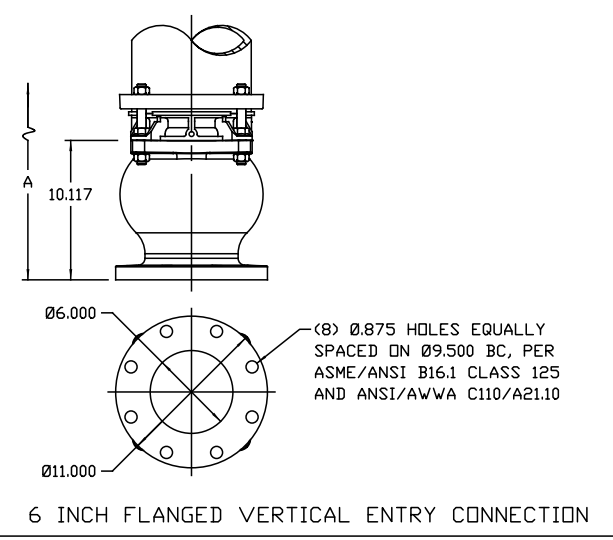
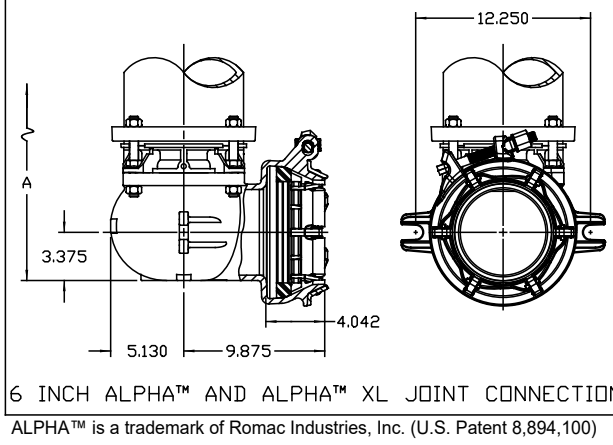
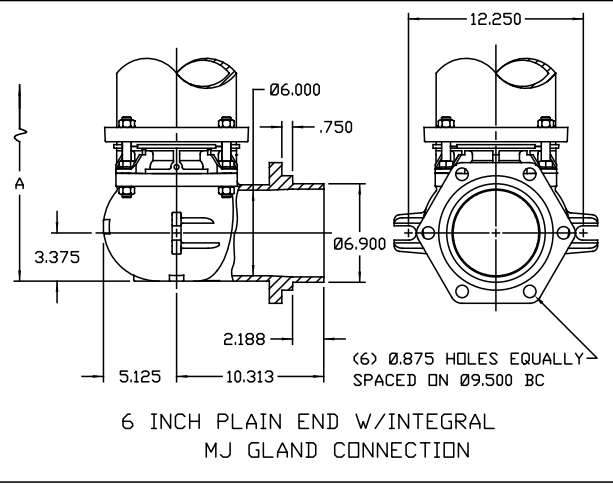
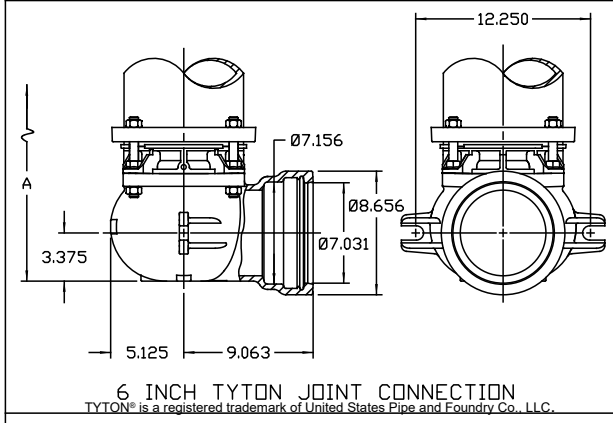
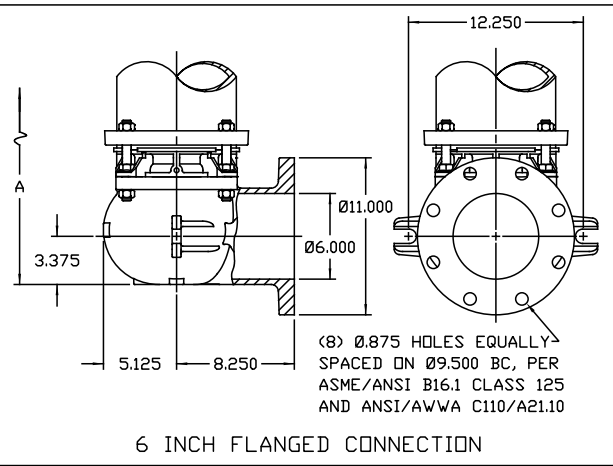
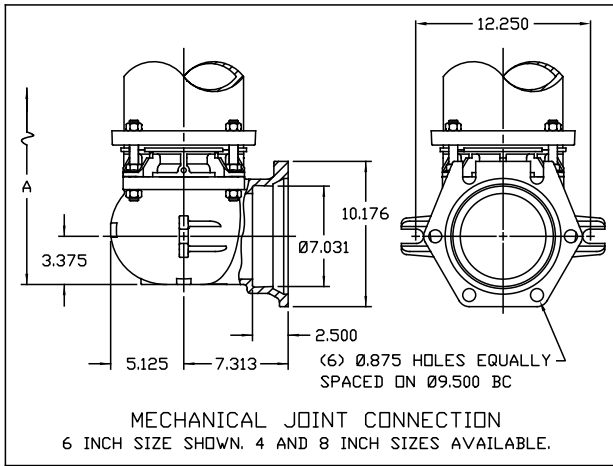

ALPHA restraint joints will accommodate the following pipe types and sizes:

ALPHA

- Ductile iron per AWWA C151
- PVC per ASTM D1785 (Schedule 40 and 80)
- PVC per ASTM D2241 (SDR 21)
- PVC per AWWA C900
- HDPE per AWWA C906 (SDR 9, 11, 13.5, and 17)

ALPHA XL

- Gray iron (Class A, B, C, and D)

Nominal Size (in)	ALPHA OD Range (in)	ALPHA XL OD Range (in)
6	6.60 - 7.00	6.90 - 7.10

NOTE: See Table 1 on Page 2A-3 for Dimension A.

4-3/4" WATEROUS TREND - OPERATING NUT SIZES

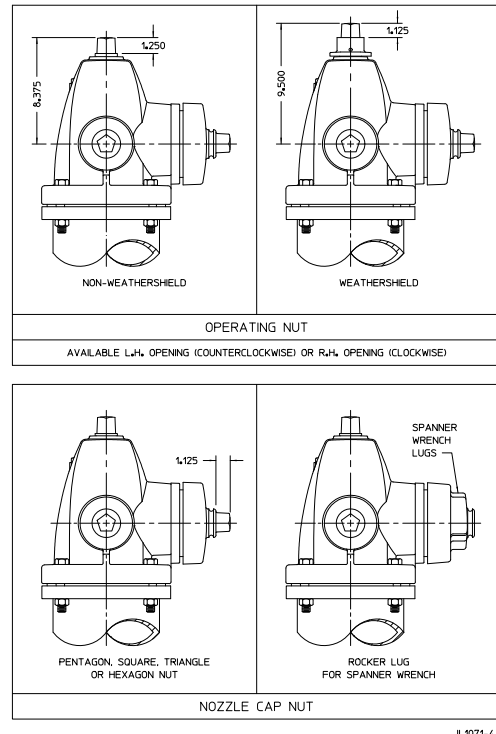
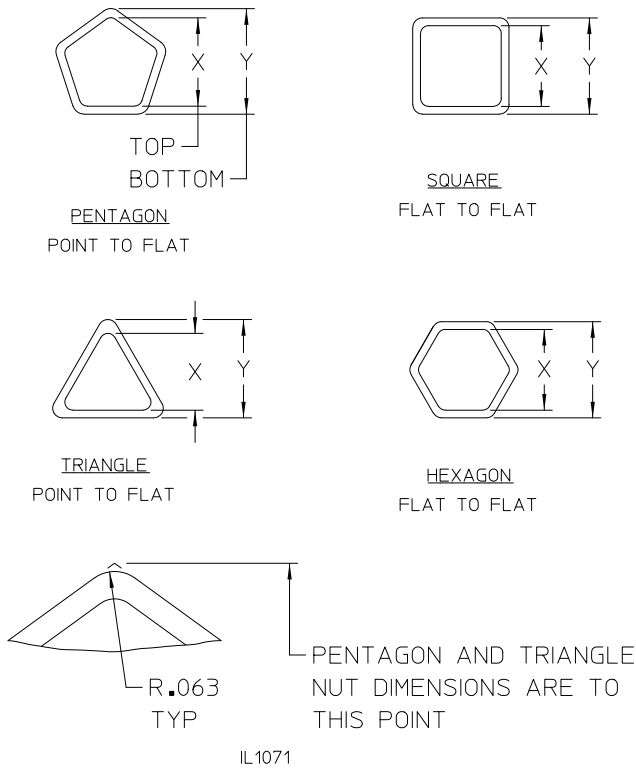

Nut Shape	Waterous Nut No.	Nominal Nut Size	X (Top)	Y (Bottom)
Pentagon	1	15/16	.866 / .835	.962 / .931
	2	1-1/8	1.059 / 1.028	1.155 / 1.124
	3	1-7/32	1.155 / 1.124	1.251 / 1.220
	3A	1-9/32	1.204 / 1.171	1.299 / 1.268
	4	1-5/16	1.251 / 1.220	1.348 / 1.317
	4A	1-3/8	1.309 / 1.278	1.406 / 1.375
	5	1-1/2	1.443 / 1.412	1.540 / 1.509
Square	6	7/8	.750 / .719	.875 / .844
	7	1	.875 / .844	1.000 / .969
Triangle	8	1-1/2	1/520 / 1.480	1.582 / 1.542
Pentagon	9	1-19/32	1.540 / 1.509	1.637 / 1.606
	*10	1-11/16	1.637 / 1.606	1.732 / 1.701
	*11	1-25/32	1.732 / 1.701	1.827 / 1.796
	*12	1-7/8	1.827 / 1.796	1.923 / 1.892
Square	13	1-1/8	1.000 / .969	1.125 / 1.094
	14	1-1/4	1.187 / 1.156	1.250 / 1.219
	*15	2	1.875 / 1.844	2.000 / 1.969
Hexagon	17	1-5/16	1.320 / 1.280	1.395 / 1.355
	17A	1-1/4	1.190	1.280
Square	19	15/16	.812 / .781	.937 / .906
Triangle	20	1-3/8	1.375 / 1.344	1.437 / 1.406
Square	*21	1-3/8	1.312 / 1.281	1.375 / 1.344
Hexagon	22	1-1/2	1.437 / 1.406	1.531 / 1.500
	22A	1-7/16	1.406 / 1.375	1.500 / 1.469
Square	*23	1-3/4	1.718 / 1.687	1.781 / 1.750
Rocker Lug	41	Rocker lug for spanner wrench (caps only)		

*NOTE: Operating nuts in these sizes are available only as weathershield type



4-3/4" WATEROUS TREND - WEIGHTS
With 6" Mechanical Joint Bottom (Less Accessories)

BURY DEPTH	WEIGHT
	TRAFFIC MODEL WB77-1
	DDP
FT - IN.	
3-0	357
3-6	377
4-0	398
4-6	418
5-0	439
5-6	458
6-0	480
6-6	500
7-0	521
7-6	541
8-0	562
8-6	582
9-0	603
9-6	623
10-0	644

NOTES:

1. Deduct 11 lbs for DD (2 hose)
2. 16 in. Breakoff Section - Use weight for 6 in. longer hydrant
3. 22 in. Breakoff Section - Use weight for 12 in. longer hydrant
4. Add 11 lbs for 4 in. Mechanical Joint accessories
5. Add 17 lbs for 6 in. Mechanical Joint accessories

4-3/4" WATEROUS TREND - FRICTION LOSS CURVE



4-3/4" Waterous Trend Hydrant Flow vs. Friction Loss

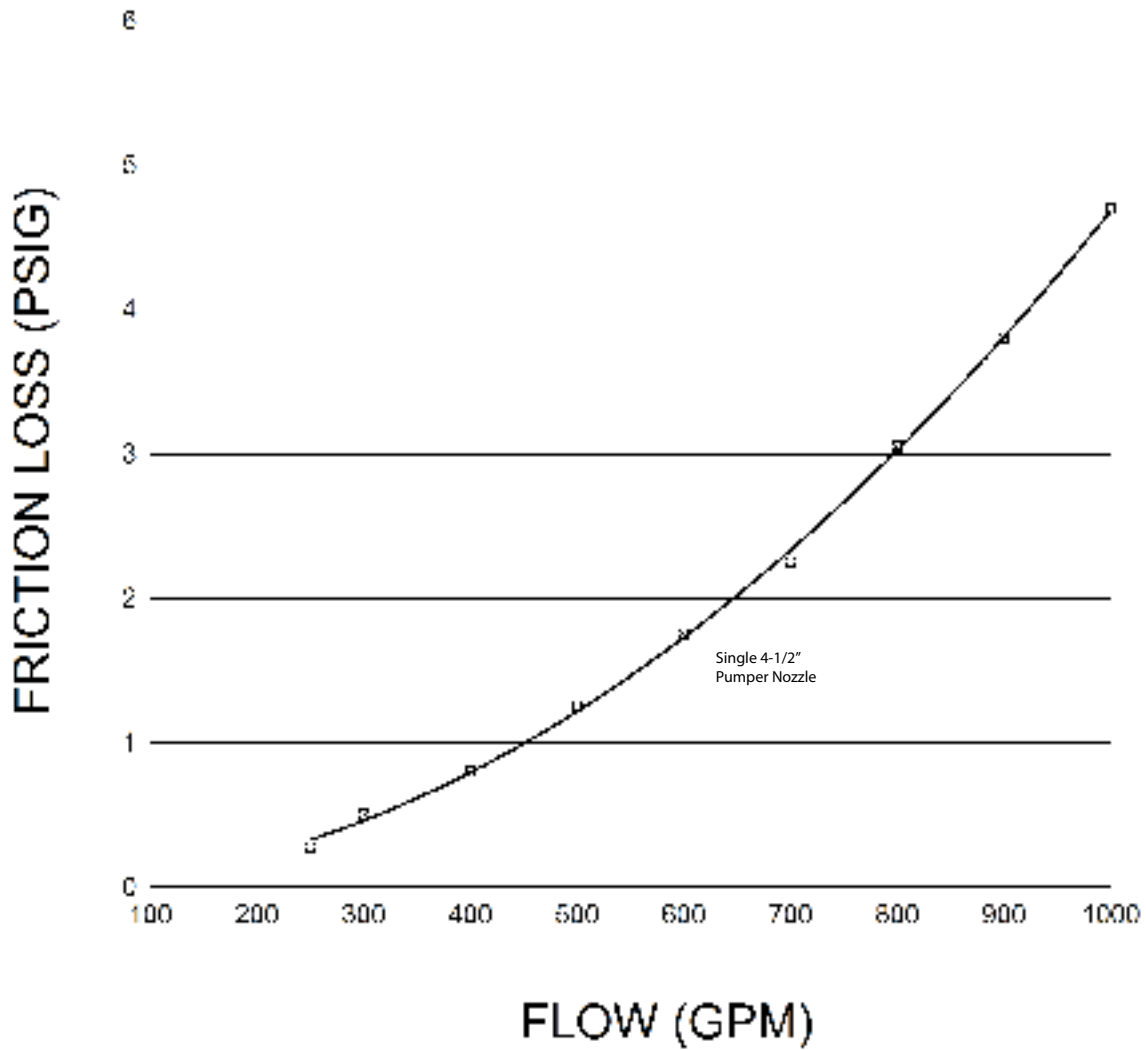

IL1072

AMERICAN Flow Control®
4-3/4" WATEROUS TREND FIRE HYDRANT
 SUBMITTAL SHEET



Date:								
City Specification:					Quantity:			
New Specification (Fill Out Entire Sheet) or			Update To Existing Specification (Only Indicate Change(s) Below)					
Type:		Traffic (Model WB77-1)		(Non-Traffic not available)				
Direction to Open:		Left (C.C.W.)		Right (C.W.)				
Operating Nuts	Operating Nut			Nozzle Cap Nuts				
	Non-Weathershield		Weathershield	Rocker Lug for Spanner Wrench or Same as Operating Nut				
	Nominal Size:	Shape:		Nominal Size:	Shape:			
	Waterous No. (If Known)			Waterous No. (If Known)				
Nozzles	Nozzle Configuration (Check One)		Pumper Nozzle		Hose or IHG Valve Nozzle			
	DDP (Two Hose, One Pumper)		Storz:	4 in.	5 in.	Nat'l Std:	Yes	No
			Nat'l Std.	Yes	No			
	DD (Two Hose)		Size:	Pitch Dia:		Size:	Pitch Dia:	
			O.D. x	T.P.I.	O.D. x	T.P.I.		
Waterous Template (If Known):			Waterous Template (If Known):					
Nozzle Cap Chains:		Yes	No		Bury Depth: (Depth of Trench)			
Upper Standpipe Length:		10"	16"	22"	28"	34"		
Bottom (Base) Connection: (Check One)								
6" Flanged		6" MJ	6" TYTON®		6" Plain End with Integral MJ Gland			
6" Flanged Vertical Entry		4" MJ	6" ALPHA™	6" ALPHA™ XL	8" MJ			
Paint Color:								
Other Requirements: (List)								

Notes:

1. Meets or exceeds requirements of AWWA C502, latest revision.
2. 250 PSIG AWWA rated working pressure.
3. Lower valve washer and hydrant bottom coated with fusion-bonded epoxy coating in accordance with ANSI/AWWA C550.
4. Certified to NSF/ANSI/CAN 61 and NSF/ANSI/CAN 372.
5. TYTON® is a registered trademark of United States Pipe and Foundry Co., LLC.
6. ALPHA™ is a trademark of Romac Industries, Inc. (U.S. Patent 8,894,100)

4-3/4" WATEROUS TREND - INSTALLATION



This instruction is issued as a recommendation to the customer for the proper use of the AMERICAN Flow Control manufactured fire hydrants. AMERICAN recommends you follow the general Inspection and Installation guidelines outlined in AWWA Manual *M17 for Installation, Field Testing, and Maintenance of Fire Hydrants* and/or as recommended below. **WARNING: Special care should be taken in the installation, inspection and repair of pressure containing devices such as valves and hydrants. FAILURE TO FOLLOW PROPER PRACTICE AND GUIDELINES CAN RESULT IN SERIOUS INJURY OR DEATH. High pressure and water hammer, due to rapid opening or closing of a hydrant or valve, can also cause major damage to the hydrant, valve, water main, fire hose, or other attached equipment.**

Receiving Inspection

On receipt, inspect for direction of opening, correct nozzle threads and operating nuts and shipping damage.

Report any problems to carrier, note on bill of lading and have the driver sign your copy.

Installation

1. When hydrants are received, they should be handled carefully to avoid breakage and damage to flanges. Keep hydrants closed until they are installed. Protect stored hydrants from the elements.
2. **Before installation of hydrant, clean piping, base and drain ring of hydrant of any rocks, sand and/or foreign material. Check for loose bolts at base, ground line and cover. Tighten if necessary.**
3. Hydrants shall be located as shown or as directed and in a manner to provide complete accessibility, and also in such a manner that the possibility of damage from vehicles or injury to pedestrians will be minimized. Locate hydrants as detailed in AWWA M17 and/or in accordance with applicable fire codes, the requirements of local fire authority, or the applicable municipal design standard.
4. All hydrants shall stand plumb and shall have their nozzles parallel with or at right angles to the curb, with the pumper nozzle facing the curb, except that hydrants having two hose nozzles 90° apart shall be set with each nozzle facing the curb at the angle of 45°. Hydrants shall be set to the established grade, with nozzles at least 18 inches above the ground, as shown or as directed by the engineer.
5. It is recommended practice to install an auxiliary or secondary gate valve in the lateral between the hydrant and the main to permit inspection and repair of the hydrant without shutting down mains. The use of AMERICAN Flow Control Series 2500 Resilient Wedge Gate Valves are recommended.
6. On traffic hydrants, surrounding soil must be adequately compacted around the standpipe to support the lower barrel against transferring the force of a vehicular impact to the base. If the soil is too sandy and will not support the loads, pour a concrete pad around the barrel at or near the ground line at least 6 inches thick and 36 inches in diameter for standpipe support.
7. Whenever a hydrant is set in soil that is pervious, drainage shall be provided at the base of the hydrant by placing coarse gravel or crushed stone mixed with coarse sand, from the bottom of the trench to at least 6 inches above the drain opening in the hydrant and to a distance of 1 foot around the elbow.
8. Whenever a hydrant is set in clay or other impervious soil, a drainage pit 2 feet in diameter and 3 feet deep shall be excavated below each hydrant and compactly filled with coarse gravel or crushed stone mixed with coarse sand under and around the elbow of the hydrant and to a level of 6 inches above the drain opening.
9. Where there is a high ground water level or other conditions that prevent the use of hydrants with drains, "non-draining" hydrants should be used. Hydrants of this type are provided with either a solid seat and/or plugged drains and are marked to pump after use. This is especially important to avoid damage to the hydrant in areas where freezing temperatures are likely. Non-draining hydrants should be checked upon installation and during semi-annual inspections to make sure the hydrant stays dry inside the lower and upper barrel.
10. Restrain hydrant movement with appropriate thrust blocking or restrained joint to prevent pipe and/or joint separation. If a concrete thrust block is installed, care should be taken to prevent blocking the hydrant drains if they are to remain operable.
11. When first installed, the hydrant should be operated from full closed to full open position and back to make sure no obstructions are present.
12. After the line, as well as the hydrant, have been hydrostatically tested, the hydrant should be flushed and checked for proper drainage, if applicable.



4-3/4" WATEROUS TREND - INSTALLATION

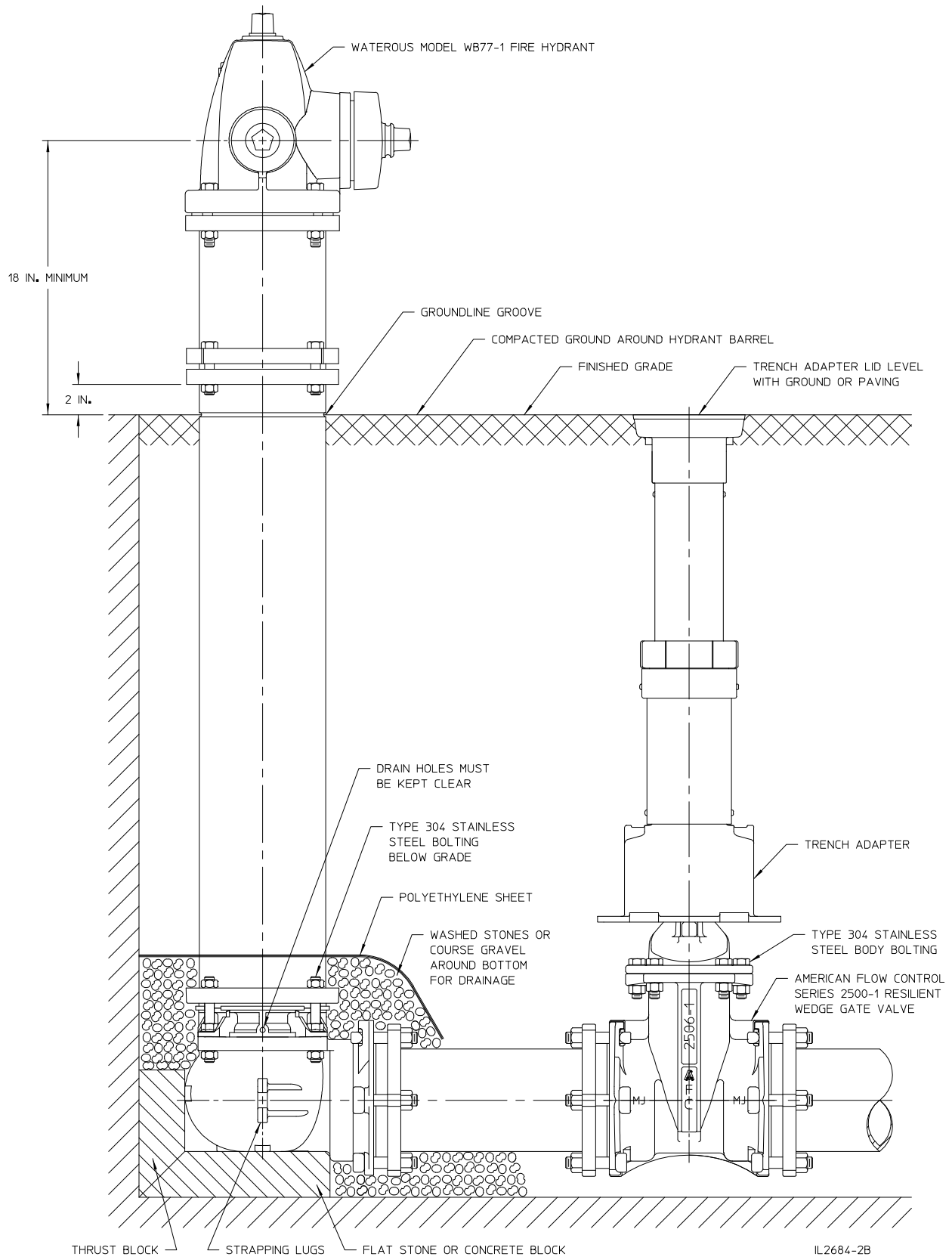

4-3/4" WATEROUS TREND TESTING



AMERICAN Flow Control recommends you follow the General Inspection and Installation Guidelines outlined in AWWA Manual M17 for Installation, Field Testing, and Maintenance of Fire Hydrants and/or as recommended below. ANSI/AWWA C502 permits dry barrel hydrants with unplugged drain outlets to have an allowable leakage of 5 fluid oz/min (0.25 mL/s) through the drain valve. Therefore, the hydrant should not be opened at the same time that the water main is tested. The auxiliary valve should be closed during water main tests (see ANSI/AWWA C600). If it is necessary to test the hydrant and water main at the same time, the installer may elect to temporarily plug the drain outlets by installing a non-draining seat. **WARNING: Special care should be taken in the installation, inspection and repair of pressure containing devices such as valves and hydrants. FAILURE TO FOLLOW PROPER PRACTICE AND GUIDELINES CAN RESULT IN SERIOUS INJURY OR DEATH. High pressure and water hammer, due to rapid opening or closing of a hydrant or valve, can also cause major damage to the hydrant, valve, water main, fire hose, or other attached equipment.** After the hydrant is installed and, when possible, before backfilling (and after pressure testing the water main), the hydrant should be tested as follows:

Pressure Test at Main Pressure

WARNING: FAILURE TO RELIEVE PRESSURE CAN RESULT IN THE CAP BLOWING OFF, CAUSING INJURY OR DEATH.

1. Remove an outlet nozzle cap and open the hydrant valve enough turns to close the drain. Allow the hydrant to fill until the water level reaches bottom of the outlet nozzle.
2. Replace the outlet-nozzle cap and leave it loose to permit all air to escape.
3. After all air has escaped, tighten the outlet-nozzle cap.
4. Open the hydrant completely. (Opening the hydrant fully before all the air has escaped will compress the air and cause a safety hazard.)
5. Check for leakage at all joints and outlet nozzles.
6. If leakage is noted, repair or replace the necessary components or the entire hydrant using the instructions found in this publication.
7. Repeat the test until results are satisfactory.

Pressure Test at Pressures Above Main Pressure

WARNING: FAILURE TO RELIEVE PRESSURE CAN RESULT IN THE CAP BLOWING OFF, CAUSING INJURY OR DEATH.

1. Connect a pressure test pump to one of the hydrant's outlet nozzles.
2. Open an outlet nozzle cap. Open the hydrant valve a few turns. Allow the hydrant to fill until the water level is at the bottom of the outlet nozzle.
3. After all the air has escaped, tighten the outlet nozzle cap.
4. Open the hydrant completely.
5. Close the auxiliary valve.
6. Safely pump up to the test pressure but do not exceed the rated working pressure of the hydrant or system components.
7. Check for leakage at all joints and outlet nozzles.
8. Safely repair or replace hydrant, if necessary, using the instructions found in this publication.
9. Repeat the test until results are satisfactory.
10. Close the hydrant and relieve pressure. Open the auxiliary valve.



4-3/4" WATEROUS TREND TESTING

Drainage Test for Dry Barrel Hydrants (Draining Type)

WARNING: FAILURE TO RELIEVE PRESSURE CAN RESULT IN THE CAP BLOWING OFF, CAUSING INJURY OR DEATH.

1. Following the pressure test, close the hydrant main valve.
2. Carefully remove one outlet nozzle cap and place the palm of one hand over the outlet nozzle opening.
3. Drainage should be sufficiently rapid to create a noticeable suction.
4. If the hydrant fails the drainage test, replace and tighten the nozzle cap, partially open the hydrant (1 or 2-turns) with the outlet nozzle caps on to create a pressure that will flush and clear the drain assembly. If this fails to restore proper drainage, then the drain assembly should be removed and inspected. If the drain assembly is clear, then the problem may be that the drain outlets are plugged from outside the hydrant. Repair will require digging down around the outside of the hydrant and clearing the drain outlets.

Placing a Hydrant Into Service

1. After testing and backfilling, the hydrant should be safely flushed and tested to be sure that it is bacteriologically safe before it is put into service.
2. Tighten the outlet nozzle caps so they will not be excessively tight, but tight enough to prevent their removal by hand.
3. Clean the hydrant exterior to remove dirt accumulated during installation. Touch up any areas where factory coating was damaged during handling or installation. Use an appropriate top coating or contact factory for touch-up coatings.

4-3/4" WATEROUS TREND OPERATION, INSPECTION, AND MAINTENANCE

Operation

AMERICAN Flow Control recommends you follow the general Inspection and Installation guidelines outlined in AWWA Manual M17 for Installation, Field Testing, and Maintenance of Fire Hydrants and/or as recommended below. The thrust bearing hydrant requires a minimum of torque to operate. **WARNING: Special care should be taken in the installation, inspection and repair of pressure containing devices such as valves and hydrants. FAILURE TO FOLLOW PROPER PRACTICE AND GUIDELINES CAN RESULT IN SERIOUS INJURY OR DEATH. High pressure and water hammer, due to rapid opening or closing of a hydrant or valve, can also cause major damage to the hydrant, valve, water main, fire hose, or other attached equipment.** It is possible to damage the hydrant by forcing it beyond its limits of travel with excess torque; therefore:

1. Check direction of opening as marked on the nozzle section.
2. To open, turn the operating nut until the main valve is fully open and the travel stop nut limits further opening. **Do not force the hydrant in the opening direction beyond fully-open as indicated by sudden resistance to turning.** If water does not flow when the hydrant is open, it is probably due to a closed valve upstream from the hydrant. Always open the hydrant completely, never only partially. A hydrant that is partially open will allow pressurized flow through the drain valve, which may wash away the soil from the area surrounding the base, or the partially open main valve may trap small stones or other debris between the valve seal and seat.
3. To close, turn the operating nut until the valve stops the flow. **It is not necessary to close this style of hydrant with great force.** Once the flow has stopped, turn the operating nut in the opening direction about 1/4 turn to take the strain off the operating parts of the hydrant. If the hydrant does not shut off completely, do not attempt to force the hydrant to close. Debris and small stones may be trapped in the valve seat and may be preventing the hydrant from closing. Partially open and close the hydrant several times to help dislodge the debris. If this does not work, safely remove the hydrant operating rod assembly, remove the debris and repair as detailed in subsequent sections of this manual.
4. **WARNING: FAILURE TO RELIEVE PRESSURE CAN RESULT IN THE CAP BLOWING OFF, CAUSING INJURY OR DEATH.** Make sure the auxiliary gate valve in the lateral between the main and the hydrant is closed and that the hydrant is not charged with pressure when removing caps.



Inspection

1. It is recommended that hydrants be inspected twice per year to ensure their satisfactory operation. After each use (especially in cold weather) hydrants should be specifically inspected for drainage.
2. Routine inspection should cover the points outlined in AWWA Manual M17 and include (but not be limited to) the following points:
 - a. External inspection of paint, caps, chains, etc.
 - b. Checking traffic type hydrants for damage to the breakaway feature.
 - c. Using a listening device to check the main valve for leakage.
 - d. Statically testing the hydrant to look for leakage at gaskets, caps, O-rings and drains.
 - e. Verifying the hydrant drains properly.
 - f. Cycling the hydrant from full open to full close.
 - g. Check for routine lubrication needs which includes but may not be limited to loss of lubricant, nozzle caps and operating mechanism.
3. At time of inspection, flush the hydrant to remove any foreign material from the hydrant and the lateral. If necessary, flush the drains by filling the hydrant and then cycling open the main valve two times to force water out of the drains under pressure. If the hydrant is non-draining type, pump water out after flushing.

MAINTENANCE

AMERICAN Flow Control strongly recommends that you follow routine maintenance on fire hydrants as outlined in AWWA Manual M17 for Installation, Field Testing, and Maintenance of Fire Hydrants. The ease of operation and the frequency of repair depends on the condition of the water system and the maintenance given. Dirt, gravel and other foreign material in the hydrant may prevent it from closing or draining properly, which may result in damage to the hydrant main valve. Under most operating conditions, AMERICAN Flow Control recommends semi-annual lubrication and inspection of fire hydrants. Where grease is specified, use an AMERICAN Flow Control recommended food grade grease.

1. Twice per year, open the hydrant completely and flush for several minutes. Open and close valve to make sure it works properly, and check for leaks.
2. Remove a cap and verify that the hydrant is draining properly. After the main valve is closed, the water in the hydrant should drain rapidly. If it does not, the drain ports may be clogged. To clear drain ports, install nozzle cap, and tighten until water tight, then open hydrant two or three turns for several minutes. This will leave drain port partially open and permit water pressure to wash out the obstruction. If this method is unsuccessful, remove the operating rod assembly and clean the drain mechanism. If neither of above methods permits water to drain, it indicates that the drainage area around the hydrant base should be rebuilt.
3. **Oil Reservoir Hydrants:**
Remove oil level plug and check oil level. The oil level should be to the level of the plug. If it is necessary to add oil, remove the oil level plug on the back of the nozzle section and add oil.
4. **Non-Oil Reservoir Hydrants:**
Remove screw from operating nut, and add approximately one tablespoon of oil through opening. Replace screw.
5. Remove all nozzle caps, clean rust or corrosion from threads of nozzles and caps, and replace cap gaskets if necessary. Apply a light coat of grease to nozzle threads before replacing cap.

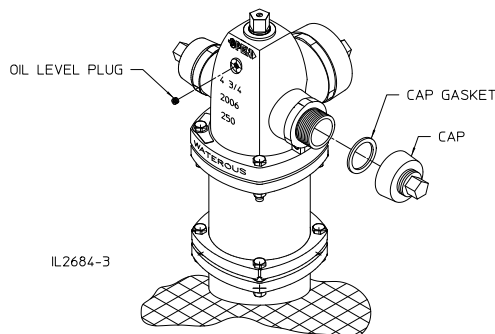

MODEL WB77-1

Note: Where oil or grease is specified, use an AMERICAN Flow Control recommended food grade lubricant.

4-3/4" WATEROUS TREND - TROUBLESHOOTING GUIDE



WARNING: Special care should be taken in the installation, inspection and repair of pressure containing devices such as valves and hydrants. FAILURE TO FOLLOW PROPER PRACTICE AND GUIDELINES CAN RESULT IN SERIOUS INJURY OR DEATH. High pressure and water hammer, due to rapid opening or closing of a hydrant or valve, can also cause major damage to the hydrant, valve, water main, fire hose, or other attached equipment.

Problem	Solution
1. Operating nut turns freely but hydrant does not open. 2. Hydrant will not shut off or ground around hydrant is highly saturated.	1. Inspect rod coupling for breakage and ensure rod pin is properly installed. 2. Close hydrant and remove nozzle cap. Check with listening device to determine if water is passing by main valve. If it is determined that the main valve is leaking, try the following: a. Flush hydrant in fully open position (watch to see if rocks or other foreign objects flush out of the barrel). b. After flushing for several minutes, shut off the hydrant. Watch for several minutes to see if flow stops. Place hand over open hose nozzle; suction should be felt, indicating hydrant is no longer leaking and drains are working properly. c. If flushing does not solve the problem, it would indicate that something is trapped or has cut the main valve rubber. Follow the seat removing instructions to replace the valve. Check threads on bronze seat to be sure that is not damaged. If threads appear worn or bent, replace the bronze seat. d. If replacing the valve does not stop the leakage, bolting at the hydrant shoe may be loose or the base gasket is damaged. The hydrant must be excavated to make the repair.
3. External leakage is noticed around the operating nut.	3. This indicates that O-rings are cut or missing. Replace o-rings as referenced in the disassembly and repair instructions.
4. Operating nut is extremely hard to turn.	4. Try to turn the operating nut. If the nut turns, carefully turn the nut back from a tight closed position until it turns freely. If it is necessary to add lubricant, for hydrants with an oil reservoir, remove the oil level plug on the back of the nozzle section and add oil. Fill oil to the level of the plug, if necessary. For hydrants with no oil reservoir, remove the flat head screw on the operating nut and add mineral oil or similar lubricant. ALWAYS FULLY OPEN AND CLOSE THE HYDRANT AFTER LUBRICATING. Replace the oil level plug or the flat head screw taking care to replace the thread sealant. The hydrant should cycle freely. If this does not solve the problem, remove the operating nut. Inspect the threads of the operating nut and upper rod. Inspect the thrust washer to ensure it is lubricated and is undamaged. Replace and/or lubricate the thrust washer if necessary. If this does not solve the problem, remove the hydrant seat and flush thoroughly. Note: Where grease is specified, use an AMERICAN Flow Control recommended food grade grease
5. Water is dripping around nozzles.	5. Close hydrant and remove nozzle cap. Replace cap gasket. Check the nozzle to be sure it is properly installed. Earlier model hydrants used caulked nozzles. Nozzle may require re-caulking or replacement of barrel. If nozzle has an O-ring behind the nozzle, it may need replacing.
6. Hydrant will not drain properly.	6. Check to be sure the water table has not risen too high to allow for drainage. Flush hydrant to be sure drains are clear. Open hydrant slowly several turns while leaving caps firmly in place to ensure hydrant drains are clear. Close hydrant and repeat this procedure. Do this slowly several times. If this does not solve the problem, remove the hydrant seat assembly and check the rubber drain facings. If no problems are found, excavate the hydrant to see if concrete or other materials have blocked the drain outlets.



4-3/4" WATEROUS TREND – IDENTIFYING VARIATIONS / REPAIR KITS

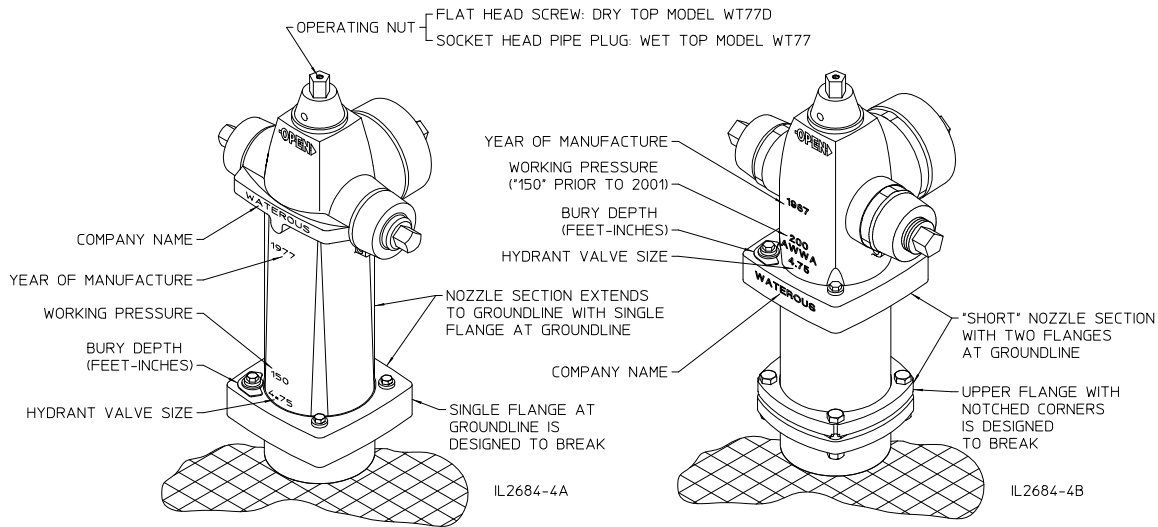

DRY TOP MODEL WT77D: BUILT FROM 1977 TO 1996
WET TOP MODEL WT77: BUILT FROM 1977 TO 1987
(SEE NOTE 6)

MODEL WB77: BUILT FROM 1987 TO 2006
(SEE NOTE 6)

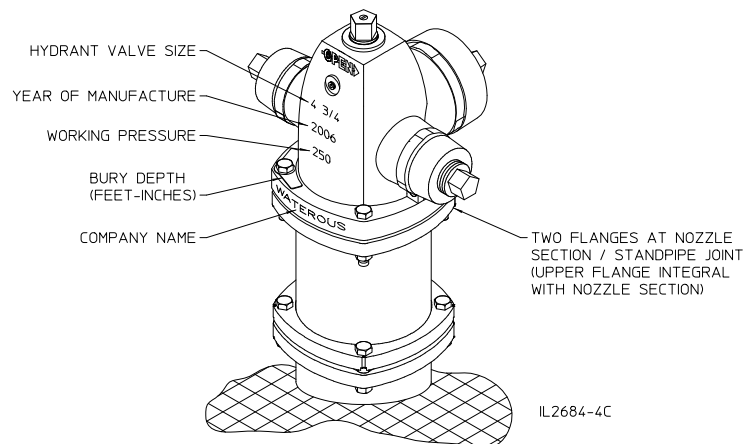

MODEL WB77-1: BUILT FROM 2006 TO PRESENT

4-3/4" TREND HYDRANT
AVAILABLE IN TRAFFIC CONFIGURATION ONLY

Repair Parts

To assure prompt delivery and shipment of the correct parts, furnish the following information with each repair parts order.

1. Date of manufacture or purchase of hydrant.
2. Depth of bury.
NOTE: Depth is shown on bury depth plate.
3. Hydrant opening direction.
4. Check original order to see if any special parts are required.
For replacement nozzles, caps, and operating nuts, be sure to furnish thread data and size and shape of nut.
5. For each part ordered, give reference number and description as found on the following parts lists.

NOTE: Kits are available for making most repairs or extending the hydrant.

6. For more information on repairs to a Trend Model WB77 built prior to mid 2006, see the following instructions:
 - 351, Installation, Operation, Maintenance and Overhaul Instructions.
 - H-358, Trend Traffic Damage Repair
 - H-404, Installation Instructions for Standpipe and Rod Extension Kit K479 in Trend Fire Hydrants.

Parts List - 250 PSIG Rated Ductile Iron 4-3/4" Waterous Trend

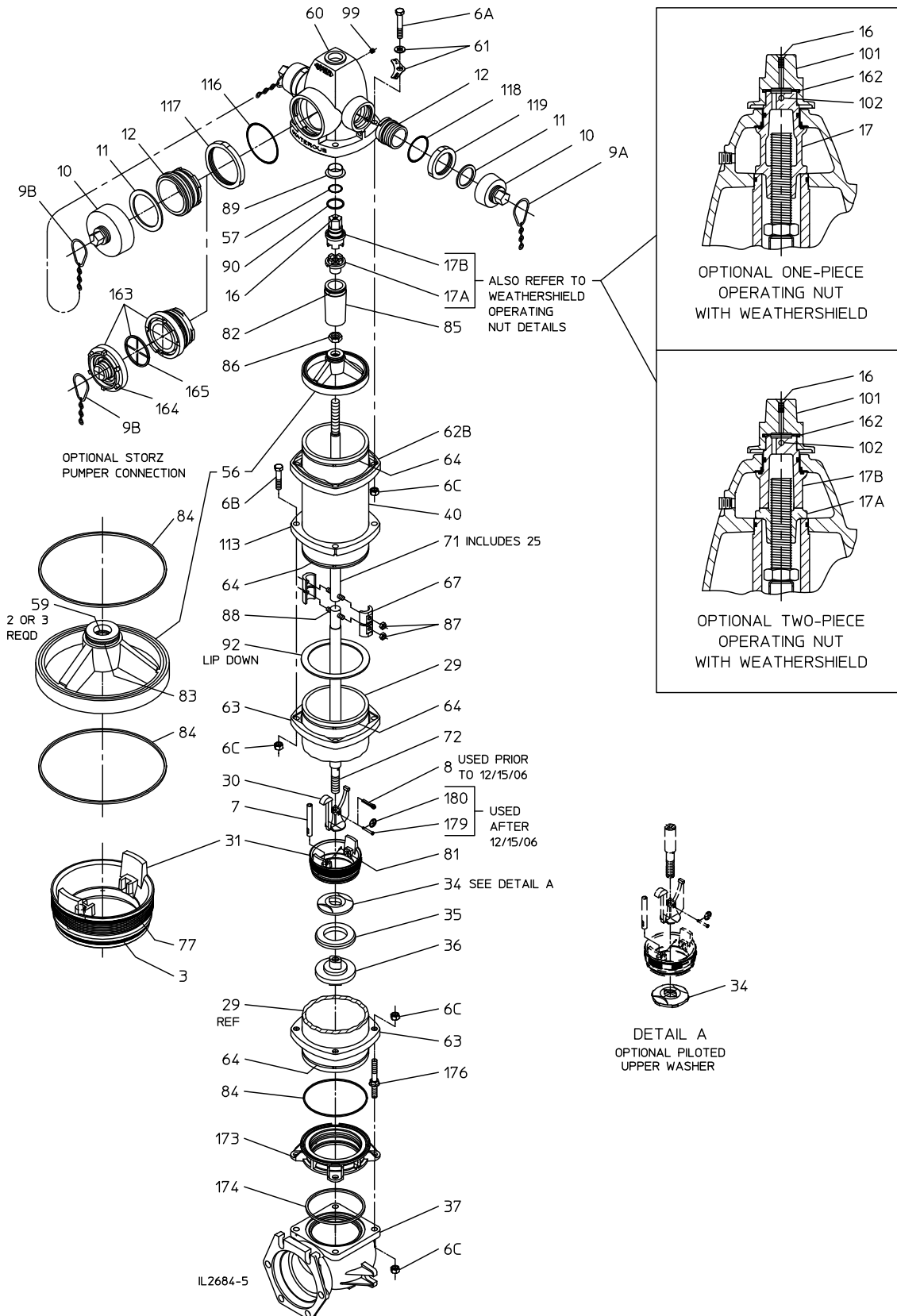

TREND MODEL WB77-1
BUILT FROM 2006 TO PRESENT

Parts List - 250 PSIG Rated Ductile Iron 4-3/4" Waterous Trend



Traffic Model WB77-1

REF NO.	DESCRIPTION	MATERIAL
3	O-ring (Lower valve seat), 5-5/8 x 6-3/64	Buna-N
6A	Hex hd bolt, 5/8-11 x 3-3/4 in.	Plated steel
6B	Hex hd bolt, 5/8-11 x 3 in.	Plated steel
6C	Hex nut, 5/8-11 (Above grade)	Plated steel
6C	Hex nut, 5/8-11 (Below grade)	Stainless steel
7	Drain plunger	Red brass
8	Cotter pin, 1/4 x 1-1/2 in.	Stainless steel
9A, 9B	Nozzle cap chain, single or double	Plated steel
10	Nozzle cap, hose or pumper	Ductile iron
11	Cap gasket, hose or pumper	Neoprene
12	Nozzle, hose or pumper	Brass
16	Flat hd screw, 1/4-20 x 1/2 in.	Stainless steel
17	Operating nut (one-piece)	Bronze
17A	Lower operating nut	Bronze
17B	Upper operating nut	Ductile iron**
25	Rod bushing	Red brass
29	Lower standpipe	Centrifugally cast ductile iron pipe*
30	Crossarm	Bronze
31	Valve seat	Bronze
34	Upper valve washer	Gray iron
35	Main valve rubber	Urethane
36	Lower valve washer	Gray iron
37	Hydrant bottom	Ductile iron
40	Upper standpipe	Centrifugally cast ductile iron pipe*
56	Support wheel	Ductile iron
57	O-ring (Operating nut), 1-1/2 x 1-3/4	Buna-N
59	O-ring (Support wheel), 1-1/8 x 1-3/8	Buna-N
60	Nozzle section	Ductile iron
61	Bury depth plate	Aluminum
61	Bury depth plate washer	Plated steel
62B	Upper standpipe flange	Ductile iron
63	Standpipe flange	Ductile iron
64	Flange lock ring	Stainless steel
67	Coupling sleeve (two-halves)	Gray iron
71	Upper rod	Steel rod
72	Lower rod	Steel rod
77	O-ring (Upper valve seat), 5-7/8 x 6-1/4	Buna-N
81	Groove pin, 3/32 x 7/16 in.	Beryllium copper
82	O-ring (Upper tube seal), 2-3/8 x 2-5/8	Buna-N
83	O-ring (Lower tube seal), 1-7/8 x 2-1/8	Buna-N
84	Support wheel / Lower standpipe gasket	Buna-N
85	Support tube	Ductile iron
86	Stop nut, 1"- 8	Plated steel
87	Coupling nut, 1/2-20	Brass
88	Coupling stud, 1/2-20 x 2-9/16 in.	Stainless steel
89	Nozzle section bushing	Brass
90	Thrust ring	Polymer bearing
92	Upper standpipe gasket	Neoprene
99	Pipe plug, 1/4 NPT	Brass
101	Weathershield nut	Ductile iron
102	Spirol pin, hvy, 1/4 x 2-1/4 in.	Stainless steel
113	Breakable flange	Ductile iron
116	O-ring (Pumper nozzle), 5-1/4 x 5-3/4	Buna-N
117	Pumper nozzle retainer	Ductile iron
118	O-ring (Hose nozzle), 3-1/4 x 3-5/8	Buna-N
119	Hoze nozzle retainer	Ductile iron
162	Weathershield nut gasket	Nitrile
163	Nozzle, pumper, Storz (with cap and gasket)	Bronze and Aluminum
164	Nozzle cap, pumper, Storz	Aluminum
165	Cap gasket, pumper, Storz	Buna-N
173	Valve seat insert	Bronze
174	Valve seat insert gasket	Nitrile
176	Stud, 5/8-11 x 5.650 in.	Stainless steel
179	Clevis pin, 1/4 x 1-11/16 in.	Stainless steel
180	Kickout ring	Stainless steel

*AWWA Standard C151 (ANSI A21.51)

**Bronze is optional on some nut sizes



Parts List - 200 PSIG Rated Gray Iron 4-3/4" Waterous Trend

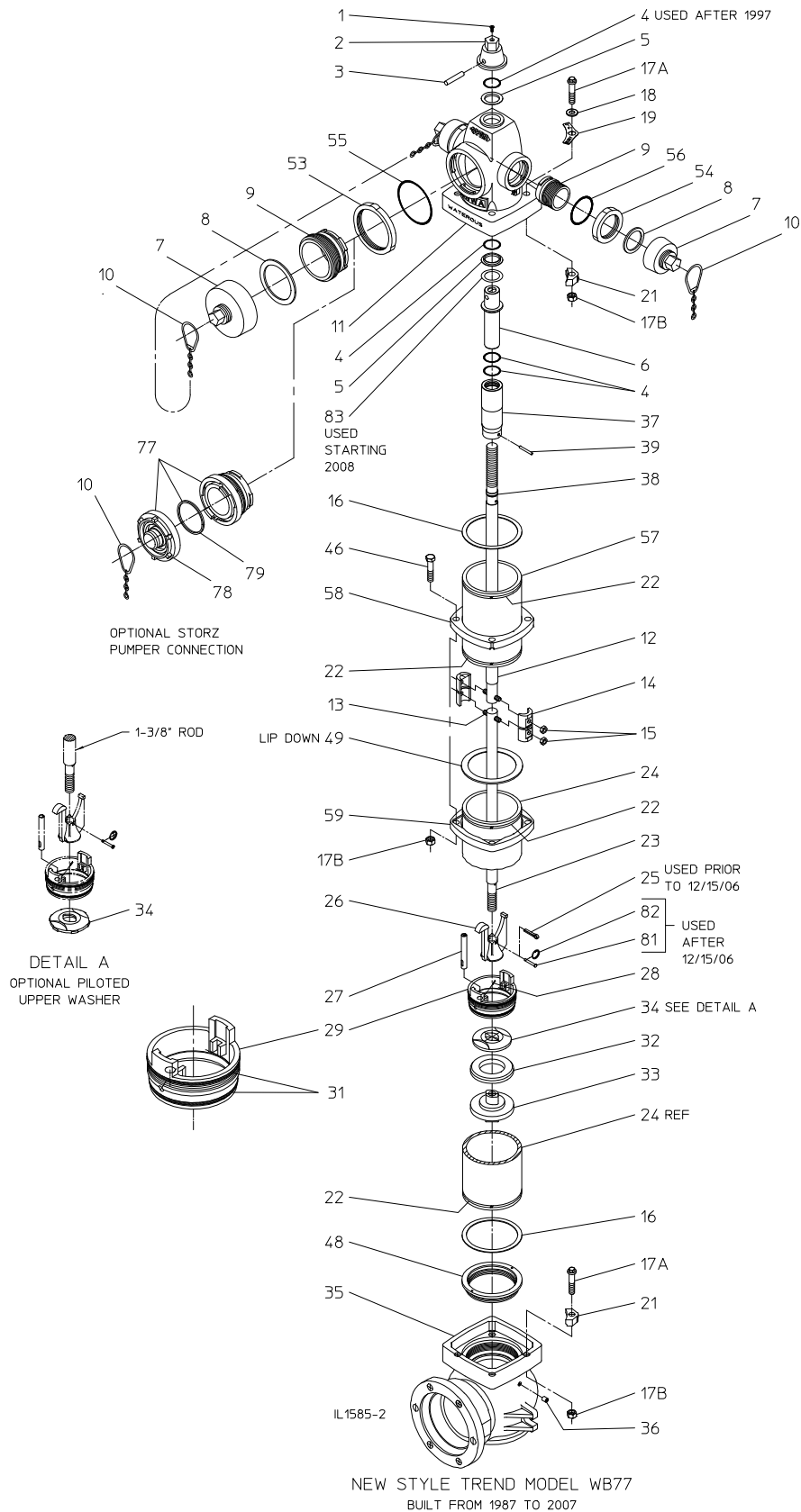



**Parts List - 200 PSIG Rated Gray Iron 4-3/4" Waterous Trend
Traffic Model WB77**

REF NO.	DESCRIPTION	MATERIAL
*1	Flat hd screw, 1/4-20 x 1/2 in.	Stainless steel
2	Weathershield nut	Gray iron
3	Spirol pin, hvy, 1/2 x 2-3/4 in.	Stainless steel
4	O-ring, 1-3/4 x 2	Buna-N
5	Thrust bushing	Sintered bronze
6	Operating nut	Brass
*7	Nozzle cap, hose or pumper	Ductile iron
*8	Cap gasket, hose or pumper	Neoprene
*9	Nozzle, hose or pumper	Bronze
*10	Nozzle cap chain, single or double	Plated steel
11	Nozzle section	Gray iron
12	Upper rod	Steel rod
*13	Coupling stud, 1/2-20 x 2-9/16 in.	Stainless steel
*14	Coupling sleeve (two halves)	Gray iron
*15	Coupling nut, 1/2-20	Brass
16	Standpipe gasket	Neoprene
*17A	Hex hd bolt, 5/8-11 x 3 in.	Plated steel
*17B	Hex nut, 5/8-11	Plated steel
*18	Bury depth plate washer	Plated steel
*19	Bury depth plate	Aluminum
*21	Lock ring clamp	Malleable iron
22	Flange lock ring	Stainless steel
*23	Lower rod	Steel rod
24	Lower standpipe	Centrifugally cast ductile iron pipe
*25	Cotter pin, 1/4 x 1-1/2 in.	Stainless Steel
26	Crossarm	Ductile iron
*27	Drain plunger	Red brass
*28	Groove pin, 3/32 x 7/16 in.	Beryllium copper
29	Valve seat	Bronze
31	O-ring, 4-7/8 x 5-1/4	Buna-N
32	Main valve rubber	Urethane
33	Lower valve washer	Gray iron
34	Upper valve washer	Gray iron
35	Hydrant bottom	Gray iron
*36	Drain bushing	Brass
37	Operating nut housing	Gray iron
38	O-ring, 1" x 1-1/4	Buna-N
39	Spirol pin, hvy, 1/4 x 2-1/4 in.	Stainless steel
*46	Hex hd bolt, 5/8-11 x 3 in.	Plated steel
48	Valve seat insert	Silicone brass
49	Upper standpipe gasket	Neoprene
*53	Pumper nozzle retainer	Ductile iron
*54	Hose nozzle retainer	Ductile iron
*55	O-ring (pumper nozzle), 5-1/4 x 5-3/4	Buna-N
*56	O-ring (hose nozzle), 3-1/4 x 3-5/8	Buna-N
57	Upper standpipe	Centrifugally cast ductile iron pipe
58	Breakable flange	Gray iron
59	Standpipe flange	Ductile iron
77	Nozzle, pumper, Storz (with cap and gasket)	Bronze and Aluminum
78	Nozzle cap, pumper, Storz	Aluminum
79	Cap gasket, pumper, Storz	Buna-N
81	Clevis pin, 1/4 x 1-11/16 in.	Stainless Steel
82	Kickout ring	Stainless Steel
83	Thrust washer (used starting 2008)	Teflon

*These parts are interchangeable with Waterous Pacer parts.



Disassembling the Hydrant

WARNING: Special care should be taken in the installation, inspection and repair of pressure containing devices such as valves and hydrants. **FAILURE TO FOLLOW PROPER PRACTICE AND GUIDELINES CAN RESULT IN SERIOUS INJURY OR DEATH.** High pressure and water hammer, due to rapid opening or closing of a hydrant or valve, can also cause major damage to the hydrant, valve, water main, fire hose, or other attached equipment.

1. **Shut off water line leading to hydrant making sure the hydrant is not under pressure. FAILURE TO FOLLOW PROPER PRACTICE AND GUIDELINES CAN RESULT IN SERIOUS INJURY OR DEATH.** Partially open hydrant valve to relieve trapped pressure. Standing to the side of the hydrant and away from the direction of the hydrant cap(s), loosen one of the hose caps to relieve any pressure that may be present in the hydrant barrel.
2. **See Figure 1, Page 2A-22**
At the nozzle section, remove bolts (6A), nuts (6C), and allow flange (62B) to slide down the upper standpipe. Depth plate and washer (61) will come off with bolts.
3. Turn upper operating nut (17B) or weathershield nut (101) in the opening direction to separate the nozzle section (60) and the support (56). Remove the nozzle section. **Caution: use proper lifting and handling techniques to avoid injury.**
4. Remove operating nut (17B or 17) from the nozzle section (60). (On hydrants with weathershield, it is necessary to drive out pin (102) and remove weathershield (101) before upper operating nut can be removed.)
5. Unscrew lower operating nut (17A - two-piece nuts, 17 - one-piece nut), and remove support tube (85).
6. Unscrew hex stop nut (86) from operating rod (71), and remove support (56).
7. Carefully lower disassembly wrench into standpipe over operating rod, and engage lugs of valve seat (31). See Figure on Page 2A-22
8. Insert a three or four foot heavy steel bar (approximately 1 in. diameter) through eye of wrench, and turn in a counterclockwise direction to remove complete operating rod and valve assembly.
9. When valve seat (31) is clear of threads in hydrant bottom (37), remove disassembly wrench and lift out operating rod assembly. **See Figure 3, Page 2A-23**
10. To disassemble lower portion of operating rod, remove cotter pin (8) or clevis pin (179) and kickout ring (180). Hold rod (72) with a pipe wrench or in a vise, and unscrew lower washer (36) with a 1-9/16 end wrench or suitable adjustable wrench. (Main valve (35), upper washer (34), valve seat (31), and cross arm (30) will come off with lower washer.) Slide drain plunger (7) from valve seat. Remove O-rings (3 and 77). Do not remove groove pin (81), which guides drain plunger, unless it is damaged.
11. Disassemble breakable coupling, unscrew nuts (87), and remove rod coupling halves (67) which join upper rod (71) to lower rod (72). Do not remove studs (88) unless they are damaged. (Breakable coupling disassembly is usually not necessary unless coupling parts are damaged.)

NOTE: When a supply of gaskets and O-rings are available, always install new ones when reassembling the hydrant. Clean dirt from O-ring grooves.

Do not drop disassembly wrench into hydrant; it may damage valve seat and related parts.



Reassembling the Hydrant

WARNING: Special care should be taken in the installation, inspection and repair of pressure containing devices such as valves and hydrants. **FAILURE TO FOLLOW PROPER PRACTICE AND GUIDELINES CAN RESULT IN SERIOUS INJURY OR DEATH.** High pressure and water hammer, due to rapid opening or closing of a hydrant or valve, can also cause major damage to the hydrant, valve, water main, fire hose, or other attached equipment.

Note: Where grease is specified, use an AMERICAN Flow Control recommended food grade grease

See Figure 1, Page 2A-22

1. Assemble breakable coupling. Slide rod coupling halves (67) onto the studs (88) in the upper and lower rods (71, 72) and install coupling nuts (87).
2. If necessary, install new groove pin (81) in valve seat (31). Slide drain plunger (7) into seat with oblong hole at lower end. Grease O-ring grooves in valve seat and install O-rings (3 and 77). Be sure to remove any twists.
3. Slide crossarm (30) and valve seat (31) on operating rod (72). Position main valve (35) and upper washer (34) on lower washer (36). Screw lower washer onto rod, engaging diamond boss on lower washer in matching recess in crossarm. Position valve seal against valve seat (35) and tighten lower washer to at least 65 ft-lbs. Tighten enough to permit installation of the clevis pin (179) and kickout ring (180).
4. Coat threads of valve seat (31) with grease. Carefully lower assembled operating rod into standpipe until valve seat rests on threads in valve seat insert. Grasping rod (71) firmly with both hands, slowly turn in a counterclockwise direction until threads engage, then turn clockwise until it is hand-tight.
5. Slowly lower disassembly wrench over operating rod (71) in standpipe, and engage it with valve seat (31). See Figure 2 on Page 2A-23. Insert a 3 or 4 foot heavy steel bar through eye of wrench and tighten valve seat securely in valve seat insert. Remove wrench.
Do not exceed 200 ft-lbs torque (50 lb pull on the end of a 4 ft bar). One person using a bar 3 to 4 feet long can easily exert enough force to tighten valve seat. Further tightening may make future seat removal more difficult.
6. Pull rod up as far as it will go (main valve will now be closed. Hold in this position while an assistant slowly turns on the water.

WARNING: To prevent serious personal injury, do not stand over rod when assistant turns on the water.

7. Visually check for possible leaks before proceeding with the next step.

See Figure 3, Page 2A-23

8. Grease O-ring and gasket grooves in support (56), and install O-rings (59), gaskets (84) and lower tube seal (83). Tape threads of operating rod (71) to protect O-rings, and install support. Remove tape from threads.
9. Install hex stop nut (86), turning it down to end of thread. Snug up with a torque of 30 ft-lbs (30 lb at end of 12 in. wrench).
10. Grease groove in upper end of support tube (85), and install upper tube seal (82). Slide tube down over operating rod (71) until it is seated on support (56).
11. Grease threads of operating rod (71) and lower bearing surface of operating nut (17A or 17). Screw lower operating nut onto rod while centering support (56) on the standpipe. Tighten operating nut (17A or 17) to securely clamp support (56) against upper standpipe (40). Be sure support (56) is centered on upper standpipe (40).
12. Grease and install thrust ring (90) and O-ring (57) in operating nut (17B or 17). If hydrant has a two-piece operating nut, set upper operating nut (17B) on lower operating nut (17A) and engage lugs in slots.
13. Carefully lower nozzle section (60) over operating nut (17b or 17) until it seats on support (56). Rotate nozzle section (60) to desired position. Install bolts (6A) and nuts (6C) through flange of nozzle section and standpipe flange (62B) and tighten finger tight. Be sure to install depth plate and washers (61) in proper position. Make sure flange (62B) is seated properly up under flange, and tighten all bolts and nuts evenly. Tighten to 60-70 ft-lbs of torque.
14. Back off operating nut slightly to release tension on operating rod. Since water pressure will hold valve up against seat, it is not necessary to turn operating nut to a dead stop if the valve and seat are in good condition.
15. Lubricate hydrant per "Lubrication" portion of the "Maintenance" section.



4-3/4" Waterous Trend Model WB77-1 - Repair Instructions

Figure 1. Repair Diagram

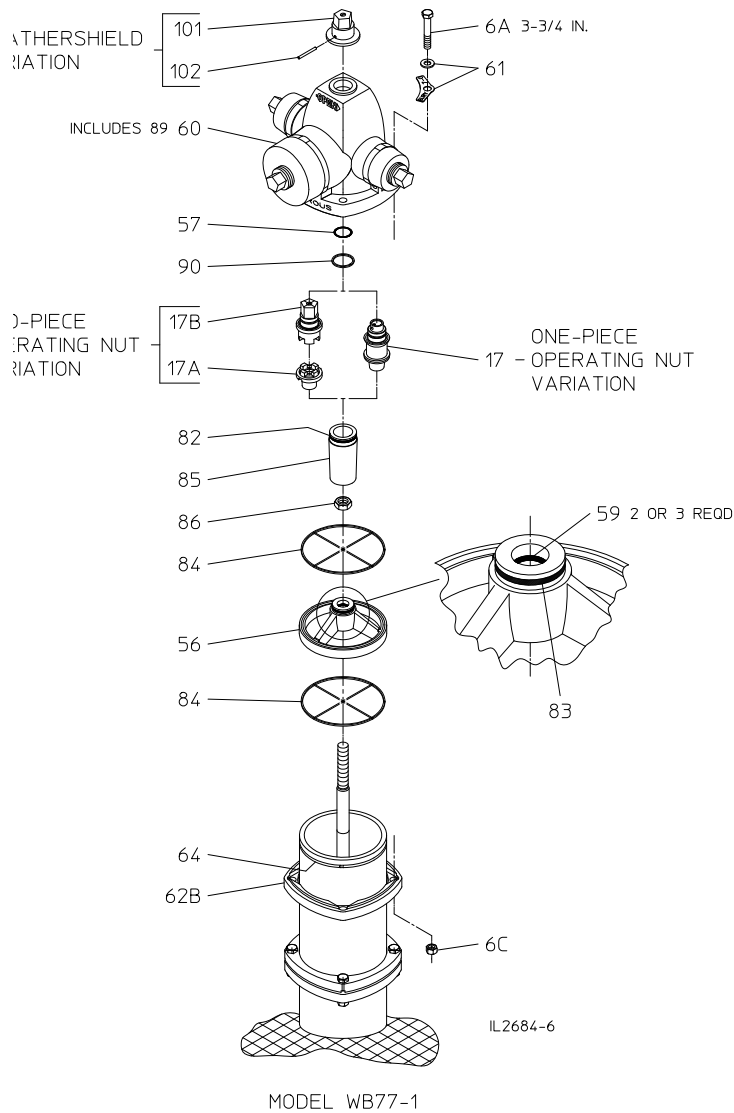
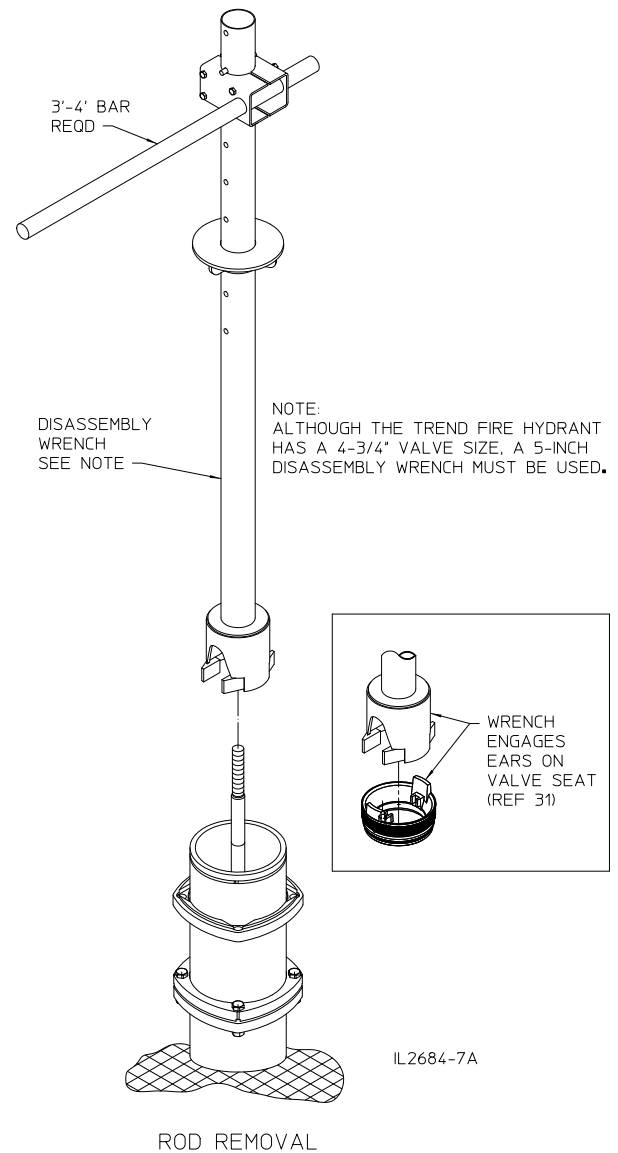

Figure 2. Rod Removal





4-3/4" Waterous Trend Model WB77-1 - Repair Instructions

Figure 3. Rod Disassembly

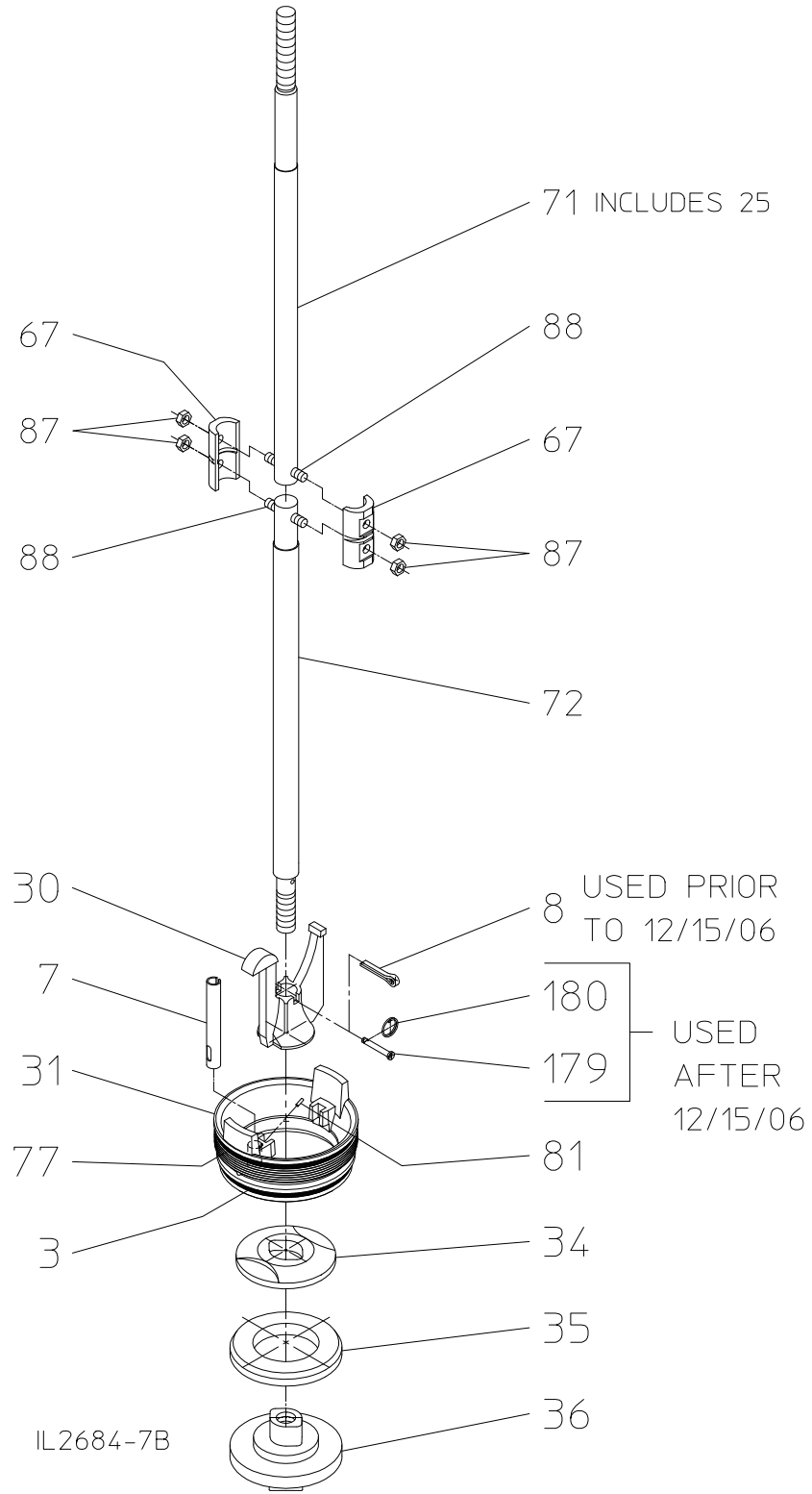

ROD DISASSEMBLY

4-3/4" Waterous Trend Model WB77-1 - Traffic Damage Repair



WARNING: Special care should be taken in the installation, inspection and repair of pressure containing devices such as valves and hydrants. FAILURE TO FOLLOW PROPER PRACTICE AND GUIDELINES CAN RESULT IN SERIOUS INJURY OR DEATH. High pressure and water hammer, due to rapid opening or closing of a hydrant or valve, can also cause major damage to the hydrant, valve, water main, fire hose, or other attached equipment.

See Figure 1, Page 2A-25

Should a hydrant be struck by a vehicle such that the upper barrel is separated / broken from the lower barrel, the following procedure should be followed to reassemble the hydrant and make it operational. (A traffic damage repair kit for the specific hydrant is required to perform this procedure.)

The extent of a traffic impact may be unknown. It is considered safe practice to close the auxilliary valve ahead of the hydrant, or use another means to cut off flow and pressure to the hydrant.

Note: Where grease is specified, use an AMERICAN Flow Control recommended food grade grease.

1. At the groundline, remove bolts (6B) and nuts (6C) which attach the upper and lower flanges. Discard the gasket, nuts and bolts.

Note: If top of the hydrant is completely broken away from the lower portion of the hydrant, step 1 may not be necessary.

2. At the nozzle section, remove bolts (6A), nuts (6C) and allow flange (62B) to slide down the upper standpipe. Depth plate and plain washer (61) will come off with bolts.
3. Turn upper operating nut (17B) or weathershield nut (101) in the opening direction separate the nozzle section (60) and the support (56). Remove the nozzle section. **Use proper handling techniques to avoid injury.**
4. Remove operating nut (17B or 17) from the nozzle section (60). (On hydrants with weathershield, it is necessary to drive out pin (102) and remove weathershield (101) before upper operating nut can be removed.)
5. Unscrew lower operating nut (17A - two- piece nuts, 17 - one-piece nut), and remove support tube (85).
6. Unscrew hex stop nut (86) from operating rod (71), and remove support (56).
7. Remove coupling nuts (87) and sleeves (67) from upper and lower rods (71 & 72). Carefully check upper rod (71) to make sure it is not bent more than 1/8 in. out of straightness. Straighten or replace if necessary. Also check studs (88) for thread damage or bending which will prevent the installation of a new coupling. Replace studs if necessary.
8. Position upper rod (71) over lower rod (72) and install new coupling halves (67). Install nuts (87) and tighten securely.

9. Remove lock ring (64) from the bottom of the upper standpipe (40). Remove old breakable flange (113) from the upper standpipe if it is still attached (in most cases, it will fracture and disengage itself from the upper standpipe). Slide new breakable flange (113) over the upper standpipe (40). Orient flange so that the larger ID of the flange will point down and properly engage the lock ring. Install lock ring (64) in the bottom groove of the upper standpipe (40). Slide flange (113) down and over the lock ring (64). See Figure 2, on Page 2A-25.
10. Place new gasket (92) on the lower standpipe with the lip pointing down. Position the upper standpipe (40) on the lower standpipe and install bolts (6B) thru flanges (113) and (63). Install nuts (6C) and tighten the four bolts evenly. Tighten to 60-70 ft-lbs of torque.
11. Grease O-ring and gasket grooves in support (56), and grease O-rings (59), gaskets (84) and lower tube seal (83). Tape threads of operating rod (71) to protect O-rings. Install support (56) onto operating rod (71), being careful not to damage O-rings on operating rod threads. Remove tape from threads.
12. Install hex stop nut (86), threading it down to end of thread. Snug up with a torque of 30 ft-lbs (30 lb at end of 12 in. wrench).
13. Grease O-ring in upper end of support tube (85). Slide tube down over operating rod (71) until it is seated on support (56).
14. Grease threads of operating rod (71) and lower bearing surface of operating nut (17A or 17). Screw lower operating nut onto rod while centering support (56) on the standpipe. Tighten operating nut (17A or 17) to securely clamp support (56) against upper standpipe (40). Be sure support (56) is centered on upper standpipe (40).
15. Grease and install thrust ring (90) and O-ring (57) in upper operating nut (17B or 17). If hydrant has a two-piece operating nut, set upper operating nut (17B) on lower operating nut (17A) and engage lugs in slots.

Note: Be sure to install the upper standpipe correctly. The groove at the top must be 3/4 in. from the end. The groove at the bottom must be 3/8 in. from the end. Also, the breakable flange (113) must be at the bottom (groundline) end of the upper standpipe. See Figure 2, on Page 2A-25.



4-3/4" Waterous Trend Model WB77-1 - Traffic Damage Repair

Using Repair Kit K528

16. Carefully lower nozzle section (60) over upper operating nut (17B or 17) until it seats on support (56). Rotate nozzle section (60) to desired position. Install bolts (6A) and nuts (6C) through flange of nozzle section and flange (62B) and tighten finger tight. Be sure to install depth plate and washers (61) in proper position. Make sure flange (62B) is seated properly with flange lock ring (64) and tighten all bolts and nuts evenly. Tighten to 60-70 ft-lbs of torque.

17. Back off operating nut slightly to release tension on operating rod. Since water pressure will hold valve up against seat, it is not necessary to turn operating nut to a dead stop if the valve and seat are in good condition.

18. Lubricate hydrant as shown in Figure 3.

Note: When a supply of gaskets and O-rings are available, always install new ones when reassembling the hydrant. Clean dirt from O-ring grooves.

Figure 1. Trend Model WB77-1

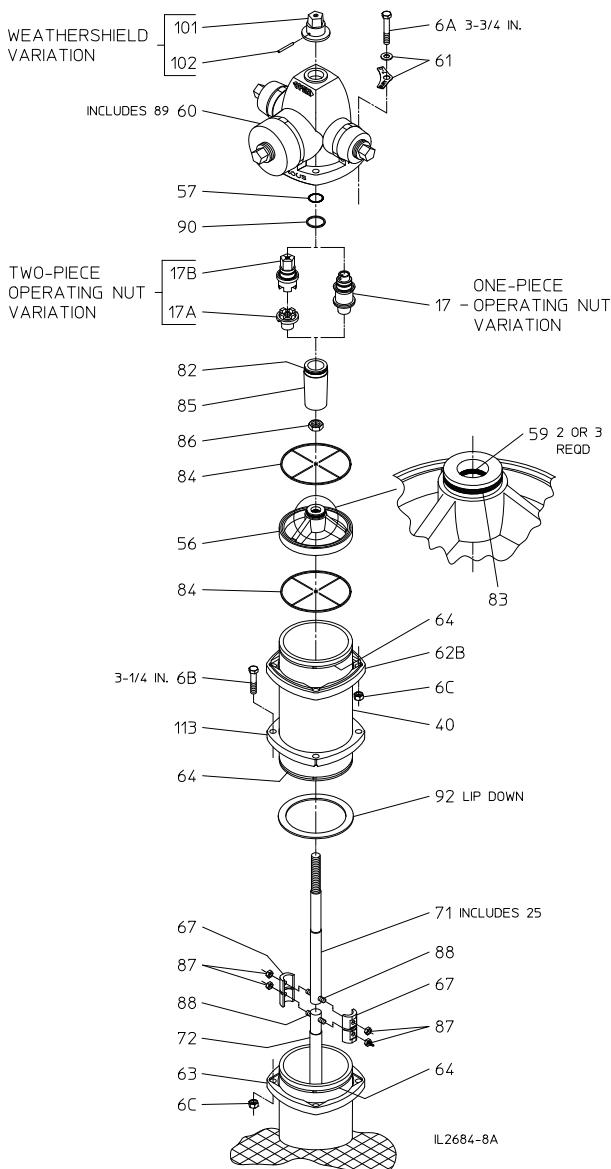

Figure 2. Upper Standpipe (Breakable Flange Orientation)

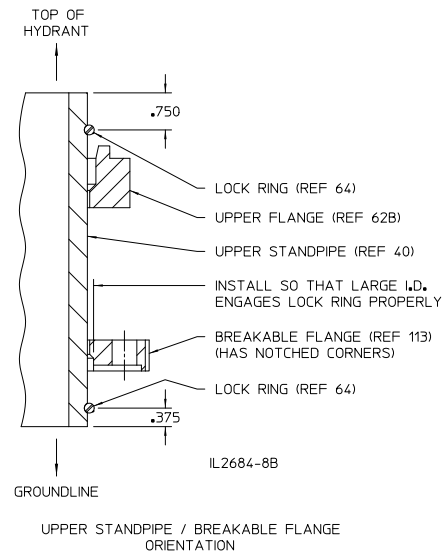
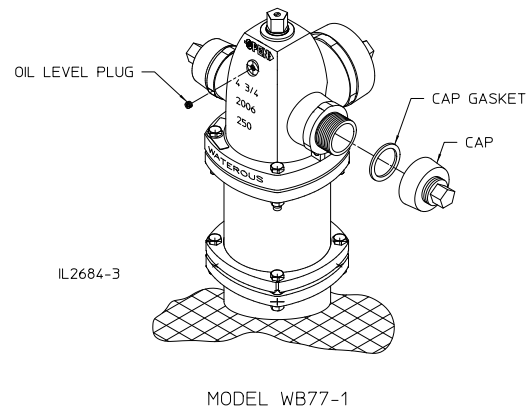

Figure 3. Lubrication Detail



1. Remove oil level plug and add oil to the level of the plug. Use an AMERICAN Flow Control recommended oil.
2. Remove all nozzle caps, clean rust or corrosion from threads of nozzles and caps. Replace cap gaskets if necessary. Apply a light coat of grease to nozzle threads before replacing cap. Use an AMERICAN Flow Control recommended food grade grease.



4-3/4" Waterous Trend - Nozzle Replacement

Mechanically Attached Nozzles

WARNING: POTENTIAL HYDRANT CAP HAZARD. FAILURE TO RELIEVE PRESSURE CAN RESULT IN THE CAP BLOWING OFF, CAUSING SERIOUS INJURY OR DEATH. Make sure the auxiliary gate valve in the lateral between the main and the hydrant is closed and that the hydrant is not charged with pressure when removing caps.

On 4-3/4" Waterous Trend fire hydrants that are equipped with Mechanically Attached nozzles, a retainer is threaded onto the nozzle, an O-ring against the face of the outlet socket of the nozzle section, creating a water tight seal.

Waterous has The following wrenches are available for removing and installing retainers.

- For Threaded Pumper Nozzles and 4-inch Storz Nozzles: Part No. 81420
- For 5 in. Storz Pumper Nozzles: Part No. 82766
- For 2½ inch Hose Nozzles: Part No. 72094

Figure 1. Mechanically Attached Nozzles

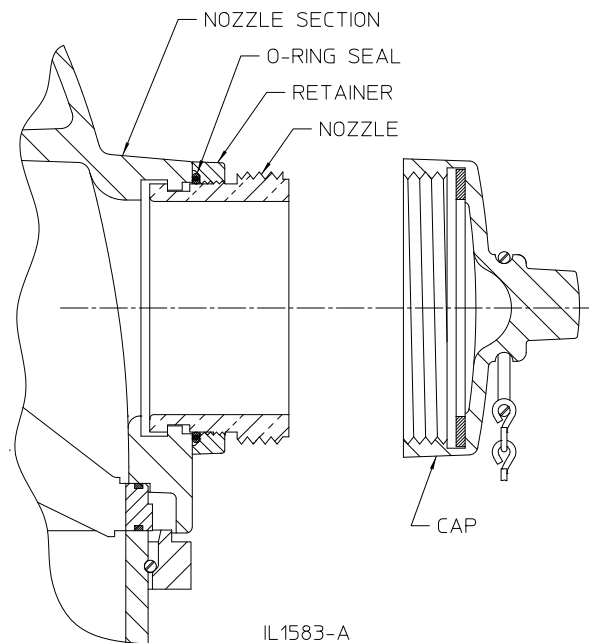

4-3/4" Waterous Trend - Nozzle Replacement Mechanically Attached Pumper Nozzle Removal



WARNING: POTENTIAL HYDRANT CAP HAZARD. FAILURE TO RELIEVE PRESSURE CAN RESULT IN THE CAP BLOWING OFF, CAUSING SERIOUS INJURY OR DEATH. Make sure the auxiliary gate valve in the lateral between the main and the hydrant is closed and that the hydrant is not charged with pressure when removing caps.

1. Carefully remove the cap while standing away from the direction of potential discharge.

2. Place wrench on the retainer so it engages the rounded protrusions and unthread from nozzle.

Removal of the 5-inch Storz hydrant nozzle requires the use of the hinged pumper-nozzle retainer wrench (Waterous Part No. 82766).

3. Rotate nozzle counterclockwise until the four lugs on the nozzle disengage the recesses in the nozzle section socket which will allow the nozzle to be removed.

Installation

1. Thread retainer onto the retainer threads of the pumper nozzle.
2. Grease O-ring and place it over nozzle starting from the end with the four lugs and into the chamfer recess in the retainer.
3. Insert the nozzle/retainer/O-ring subassembly into the socket in the nozzle section. Rotate the subassembly clockwise until it stops with the four lugs on the nozzle fully engaged in the anti-rotation recesses in the socket. If it cannot be rotated, turn the retainer in a direction to allow the nozzle to be inserted further into the socket so the subassembly rotates clockwise against the stops.
4. Hand tighten the retainer to press O-ring against the face of the socket.

5. Place the nozzle wrench on the retainer so it engages the rounded protrusions. Tighten the retainer to between 200 – 250 ft-lbs.

Installation of the 5-inch Storz hydrant nozzle requires the use of the hinged pumper-nozzle retainer wrench (Waterous Part No. 82766).

6. Clean rust or corrosion from cap threads and replace cap gasket if necessary. Apply a light coat of grease to the nozzle threads and install the cap.
7. Cap all nozzles and open the hydrant valve, check the area around the repaired nozzle for leaks.

NOTE: Where grease is specified, use an AMERICAN Flow Control recommended food grade grease.

Figure 2. Mechanically Attached Pumper Nozzle

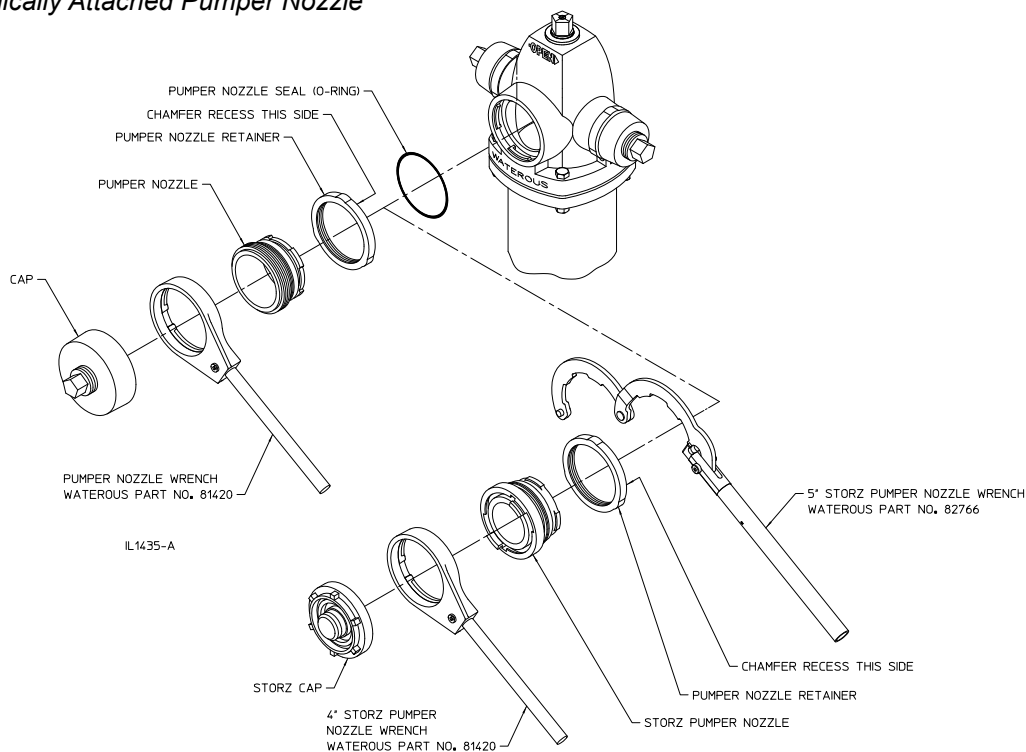



4-3/4" Waterous Trend - Nozzle Replacement Mechanically Attached 2-1/2" Hose Nozzle

Removal

WARNING: POTENTIAL HYDRANT CAP HAZARD. FAILURE TO RELIEVE PRESSURE CAN RESULT IN THE CAP BLOWING OFF, CAUSING SERIOUS INJURY OR DEATH. Make sure the auxiliary gate valve in the lateral between the main and the hydrant is closed and that the hydrant is not charged with pressure when removing caps.

1. Carefully remove the cap while standing away from the direction of potential discharge.

2. Place wrench on the retainer so it engages the rounded protrusions and unthread from nozzle.
3. Rotate nozzle counter-clockwise until the two lugs on the nozzle disengage the recesses in the nozzle section socket which will allow the nozzle to be removed.

Installation

1. Insert hose nozzle into the socket of the nozzle section, turn clockwise until it stops with the two lugs on the nozzle fully engaged in the anti-rotation recesses in the socket.
2. Grease O-ring and place it over the nozzle and against the face of the socket.
3. Thread retainer onto the hose nozzle and hand tighten to press the O-ring against the face of the socket.

4. Place the nozzle wrench on the retainer so it engages the rounded protrusions. Tighten the retainer to between 100 – 150 ft-lbs.
5. Clean rust or corrosion from cap threads and replace cap gasket if necessary. Apply a light coat of grease to the nozzle threads and install the cap.

NOTE: Where grease is specified, use an AMERICAN Flow Control recommended food grade grease.

Figure 3. Mechanically Attached Hose Nozzle

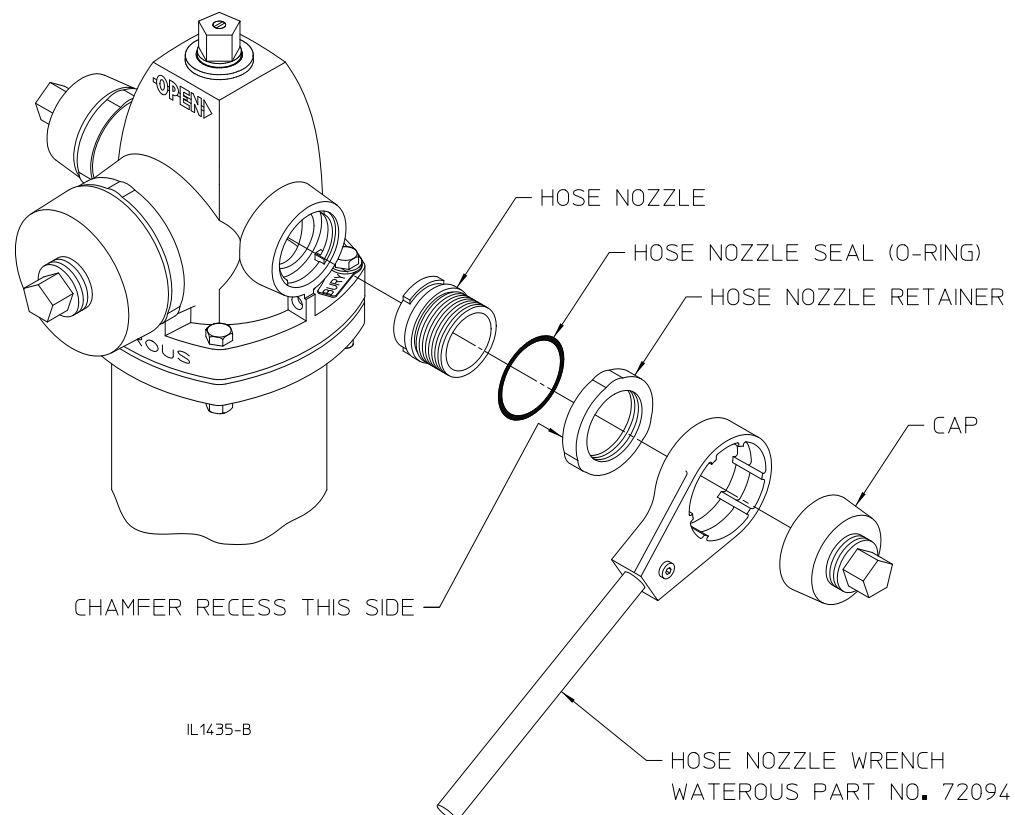



4-3/4" Waterous Trend Model WB77-1 - Extension Instructions Using Standpipe and Rod Extension Kit K562

Identification Diagram

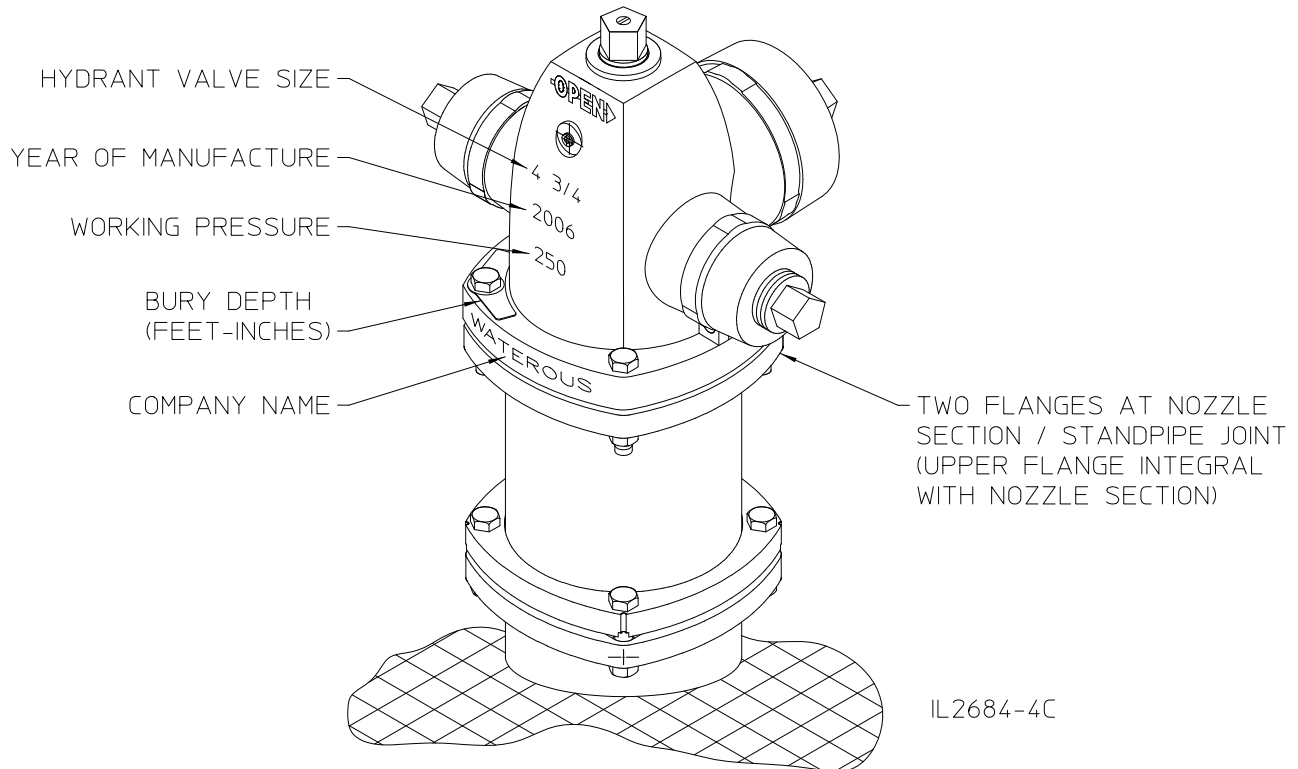

MODEL WB77-1: BUILT FROM 2006 TO PRESENT

Important Notes

1. AMERICAN recommends a new rod corresponding to the extended bury or cover depth be installed in place of a rod extension if the hydrants meet one or more of the following criteria:
 - a. The length of the rod extension required exceeds 4 ft-0 in..
 - b. The hydrant has already been extended. Only one rod extension per hydrant is recommended.
2. If extended depth of hydrant will exceed 11 ft-6 in. bury, a "bottom extension" should be installed in place of a standpipe and rod extension.
3. Contact AMERICAN for appropriate parts and guidance if any of the above situations exist.

4-3/4" Waterous Trend Model W77B-1 – Extension Instructions Using Standpipe and Rod Extension Kit K562



WARNING: Special care should be taken in the installation, inspection and repair of pressure containing devices such as valves and hydrants. FAILURE TO FOLLOW PROPER PRACTICE AND GUIDELINES CAN RESULT IN SERIOUS INJURY OR DEATH. High pressure and water hammer, due to rapid opening or closing of a hydrant or valve, can also cause major damage to the hydrant, valve, water main, fire hose, or other attached equipment.

Note: Where grease is specified, use an AMERICAN Flow Control recommended food grade grease.

1. Close hydrant valve. It is considered safe practice to close the auxiliary valve ahead of the hydrant, or use another means to cut off flow and pressure to the hydrant. Always standing to the side of the hydrant and away from the direction of the hydrant caps, loosen one of the hose caps to relieve any pressure that may be present in the hydrant barrel. **WARNING: FAILURE TO RELIEVE PRESSURE CAN RESULT IN THE CAP BLOWING OFF, CAUSING SERIOUS INJURY OR DEATH.**
See Figure 2 , Page 2A-31
2. At the nozzle section, remove bolts (6A), nuts (6C), and allow flange (62B) to slide down the upper standpipe. Depth plate and washer (61) will come off with bolts.
3. Turn upper operating nut (17B) or weathershield nut (101) in the opening direction to separate the nozzle section (60) and the support (56). Remove the nozzle section, lifting upwards. **Use proper handling and lifting techniques to avoid injury.**
4. Remove operating nut (17B or 17) from the nozzle section (60). (On hydrants with weathershield, it is necessary to drive out pin (102) and remove weathershield (101) before upper operating nut can be removed.)
5. Unscrew lower operating nut (17A - two- piece nuts, 17 - one-piece nut), and remove support tube (85).
6. Unscrew hex stop nut (86) from operating rod (28), and remove support (56).
7. Remove bolts (6B) and nuts (6C) and lift off upper standpipe (40). Discard gasket (92), bolts (6B) and nuts (6C). Note that flange (113) and (62B) will remain attached to the upper standpipe (40). It is not necessary to remove these flanges. They may remain on the upper standpipe.
8. Safely disassemble breakable coupling. Unscrew nuts (87) and remove rod coupling halves (67) which join the upper rod (71) to the lower rod (72). Do not remove studs (88) unless they are damaged.
9. Install rod extension (74) on existing lower rod (72) using extension couplings (174). Slide coupling halves (174) onto studs in rod extension (74) and lower rod (72) and install nuts (87). Note: Be sure extension couplings are installed at the original ground line. Refer to Figure 4 on Page 2A-31.
10. Install flanges (63) and lock rings (64) onto standpipe extension (45). Be sure to orient flanges properly. Refer to Figure 3 on Page 2A-31.
11. Install gasket (92) on existing standpipe with lip pointing down. Install standpipe extension (45) on existing standpipe. Install bolts (6D) and nuts (6C) thru flanges (63) and tighten finger tight. Make sure flanges (63) are seated properly on lock rings (64) and tighten all bolts and nuts evenly. Tighten to 60-70 ft-lbs torque.
12. Install existing upper rod (71) onto rod extension (74) using breakable couplings (67). Slide coupling halves (67) onto studs in rod extension (74) and upper rod (71) and install nuts (87). Note: Be sure breakable couplings are installed at the new ground line. Refer to Figure 4 on Page 2A-31.
13. Install gasket (92) on standpipe extension (45) with lip pointing down. Install existing upper standpipe (40) on standpipe extension. Install bolts (6B) and nuts (6C) thru flanges (113) and (63) and tighten finger tight. Be sure flanges engage lock rings (64) properly and tighten all bolts and nuts evenly. Note that breakable flange (113) must be on the bottom of the upper standpipe. Also, upper standpipe (40) must be installed properly with the groove 3/4 in. from the end at the top and the groove 3/8 in. from the end at the bottom. Refer to Figure 4 on Page 2A-31.
14. Grease O-ring and gasket grooves in support (56), and grease O-rings (59), gaskets (84) and lower tube seal (83). Tape threads of operating rod (71) to protect O-rings. Install support (56) onto operating rod (71), being careful not to damage O-rings on operating rod threads. Remove tape from threads.
15. Install hex stop nut (86), turning it down to end of thread. Snug up with a torque of 30 ft-lbs (30 lb at end of 12 in. wrench).
16. Grease O-ring in upper end of support tube (85). Slide tube down over operating rod (71) until it is seated on support (56).
17. Grease threads of operating rod (71) and lower bearing surface of operating nut (17A or 17). Screw lower operating nut onto rod while centering support (56) on the standpipe. Tighten operating nut (17A or 17) to securely clamp support (56) against upper standpipe (40). Be sure support (56) is centered on upper standpipe (40).
18. Grease and install thrust ring (90) and O-ring (57) in operating nut (17B or 17). If hydrant has a two piece operating nut, set upper operating nut (17B) on lower operating nut (17A) and engage lugs in slots.



4-3/4" Waterous Trend Model WB77-1 - Extension Instructions

Using Standpipe and Rod Extension Kit K562

19. Carefully lower nozzle section (60) over operating nut (17b or 17) until it seats on support (56). Rotate nozzle section (60) to desired position. Install bolts (6A) and nuts (6C) through flange of nozzle section and flange (62B) and tighten finger tight. Be sure to install depth plate and washers (61) in proper position. Also install extension plate (157) opposite the bury depth plate (see Figure 5 on Page 2A-32). Make sure flange (62B) is seated properly with lock ring (64) and tighten all bolts and nuts evenly. Tighten to 60-70 ft-lbs of torque.

20. Back off operating nut slightly to release tension on operating rod. Since water pressure will hold valve up against seat, it is not necessary to turn operating nut to a dead stop if the valve and seat are in good condition.

21. Lubricate hydrant as shown in Figure 6 on Page 2A-32.

Note: When a supply of gaskets and O-rings are available, always install new ones when reassembling the hydrant. Clean dirt from O-ring grooves.

Installation Diagram - Trend Model WB77-1

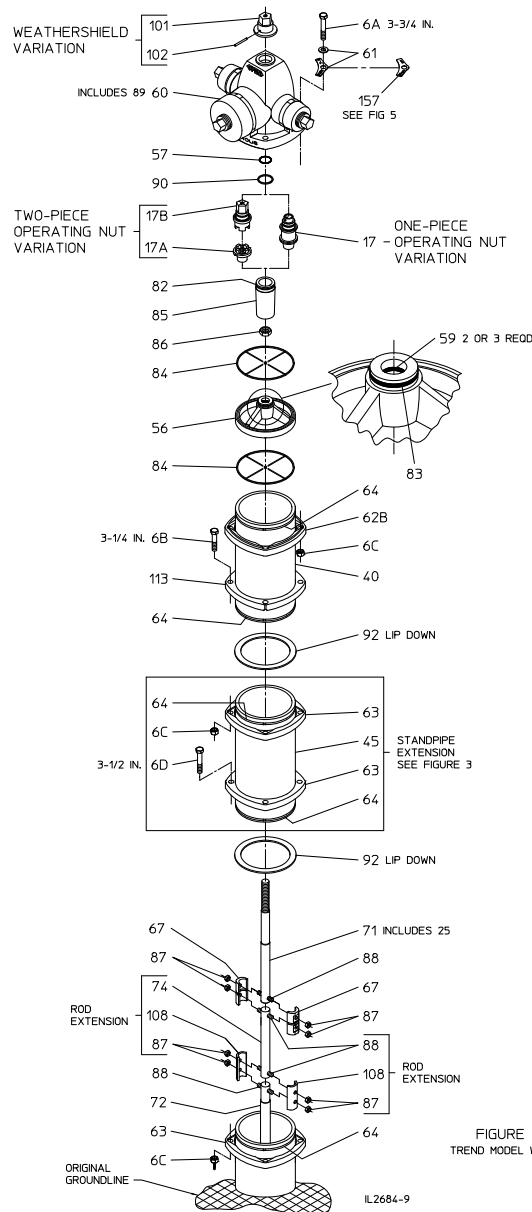

FIGURE 2
TREND MODEL WB77-1



4-3/4" Waterous Trend Model WB77-1 - Extension Instructions

Using Standpipe and Rod Extension Kit K562

Figure 3. Standpipe Extension / Flange Orientation

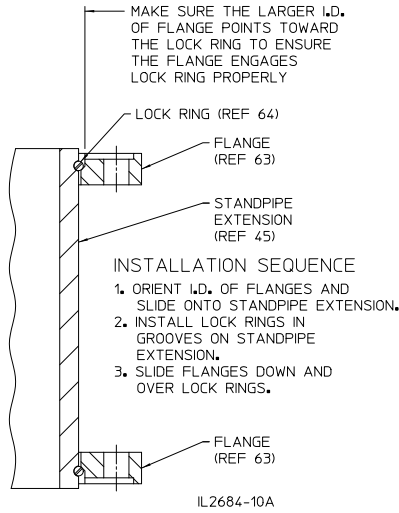

Figure 5. Extension Plate Installation

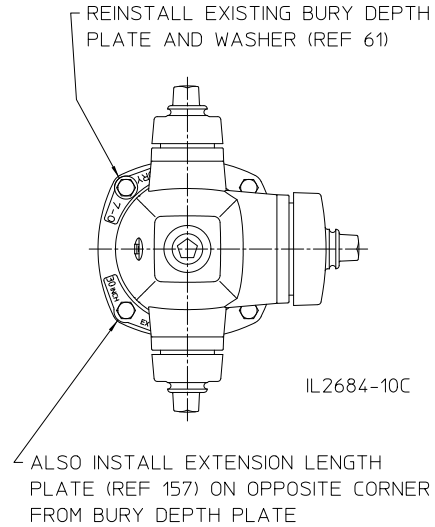

Figure 4. Extension Parts / Existing Parts Orientation

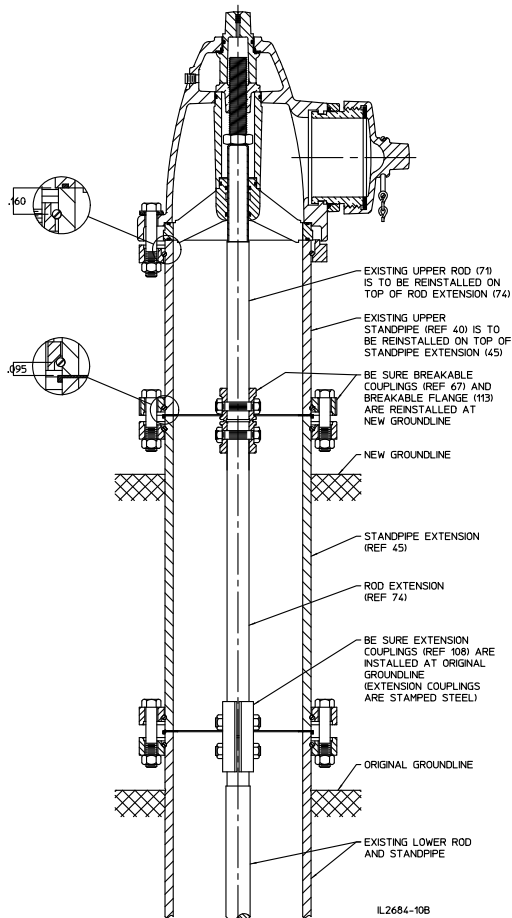
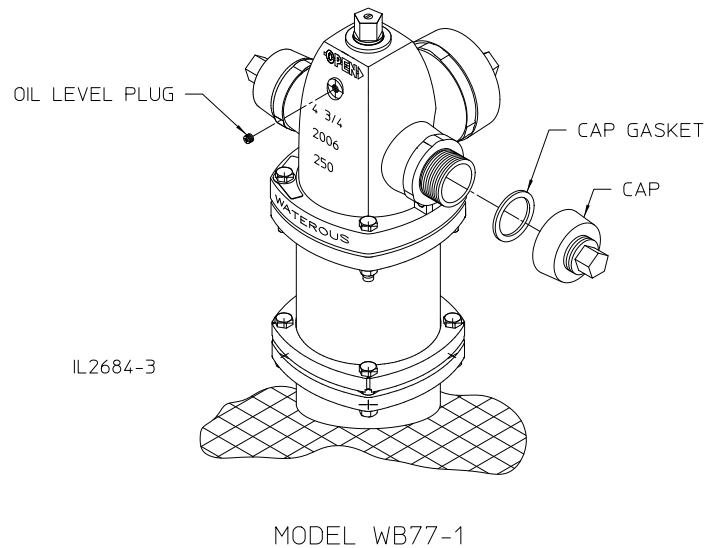

Figure 6. Lubrication Detail



1. Remove oil level plug. Add oil to the level of the plug. Use an AMERICAN Flow Control recommended oil.
2. Remove all nozzle caps, clean rust or corrosion from threads of nozzles and caps. Replace cap gaskets if necessary. Apply a light coat of grease to nozzle threads before replacing cap. Use an AMERICAN Flow Control recommended food grade grease.

4-3/4" WATEROUS TREND SPECIFICATIONS



Fire hydrants shall meet or exceed ANSI/AWWA C502, latest revision. Rated working pressure shall be 250 psig, test pressure shall be 500 psig and hydrants shall include the following specific design criteria:

- The nozzle section, upper and lower stand pipes and hydrant base shall be ductile iron.
- External surfaces above grade shall be factory coated with an epoxy primer and a two-part polyurethane top coating. Lower valve washer and hydrant bottom coated with fusion-bonded epoxy coating in accordance with ANSI/AWWA C550.
- The main valve closure shall be of the compression type, opening against the pressure and closing with the pressure. Nozzle section to be designed for easy 360° rotation by the loosening of no more than four bolts.
- The valve opening diameter shall be 4-3/4 in.. Hydrant must be designed so that removal of all working parts can be accomplished without excavating. The bronze seat shall be threaded into mating threads of bronze for easy field repair.
- Bolting below grade shall be stainless steel.
- The draining system of the hydrant shall be bronze and be positively activated by the main operating rod. Hydrant to be furnished with a sliding bronze drain valve. Sliding drain valves made of rubber, plastic or leather will not be allowed.
- Hydrant must have an internal travel stop nut located in the top housing of the hydrant.
- Hydrant operating threads to be factory lubricated. O-rings shall be furnished to help keep operating threads lubricated and protected from line fluid and from the weather.
- Hydrant must have a traffic flange design allowing for quick and economical repair of damage resulting from a vehicle's impact.
- Hydrants shall be the **4-3/4" Waterous Trend (Model WB77-1)** by AMERICAN Flow Control.



AMERICAN

FLOW CONTROL

THE RIGHT WAY

AMERICAN Flow Control

P.O. Box 2727
Birmingham, AL 35202-2727
Phone: 800-326-8051
Fax: 800-610-3569
Email: afcsales@american-usa.com

Waterous Company

125 Hardman Avenue South
South St. Paul, MN 55075-2421
Phone: 888-266-3686
Fax: 800-601-2809
Email: afcsales@american-usa.com

WWW.AMERICAN-USA.COM



Product literature may become outdated. AMERICAN is not responsible for out-of-date information, errors or omissions.
Please contact AMERICAN for the most current product information.